

# PRODUCT SUBMITTAL

## 301AP Annunciator Panel



### ORDERING INFORMATION

#### 301AP Annunciator Panel

301AP

### 301AP - SPECIFICATIONS

<b>Power Requirements:</b>	17 - 24 Vac, 24 - 38 Vdc
<b>Operating Temperature Range:</b>	0 to 40°C (32°F to 104°F)
<b>Operating Humidity Range:</b>	0 to 95% RH, non-condensing
<b>Standard Outputs :</b>	3 DPDT relays
<b>Relay Specifications:</b>	5A, 30Vdc or 250 Vac (resistive load)
<b>Audible alarm:</b>	65dB at 3 feet
<b>Communication:</b> (length of lines)	Up to 2000 feet (609m) per channel
<b>Enclosure:</b>	NEMA 4X ABS and polycarbonate
<b>Dimensions:</b>	8 in (H) x 9.5 in (L) x 2.5 in (D) 20,3 cm (H) x 24.4 cm (L) x 5,7 cm (D)
<b>Weight:</b>	2.4 lbs (1.088 kg)

# PRODUCT SUBMITTAL

## 301AP Annunciator Panel



### INSTALLATION INSTRUCTIONS

Installation instructions must be strictly followed to ensure the proper functioning of the equipment. Honeywell will not be liable or responsible for any malfunctions or incidents that may occur from improper installation:

- Place each unit in a location that is easily accessible for service.
- Avoid placing units near sources of vibrations.
- Avoid placing units near equipment that emits electromagnetic interference.
- Avoid any location where there are large temperature swings.
- Before installing, verify all local codes, standards or legislation that could impact choice of installation location.

### WALL MOUNT INSTALLATION INSTRUCTIONS

The unit should be mounted on a wall away from heat and with sufficient ventilation room around the unit.

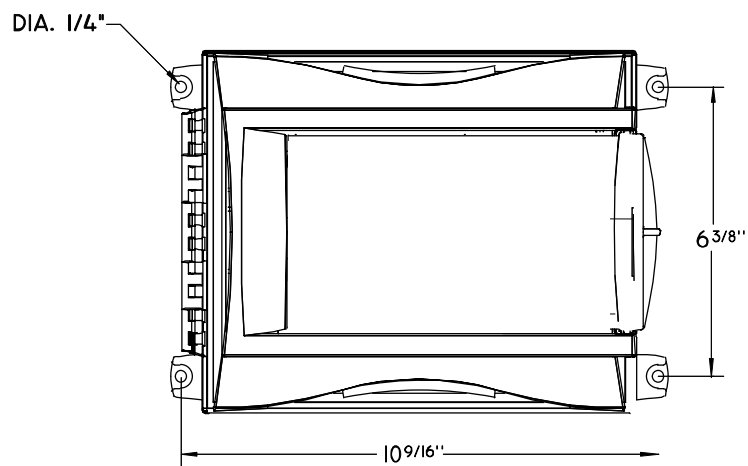

1. Select installation location
2. Measure and mark mounting holes (as shown)
3. Pre-drill or prepare as required by mounting surface (drywall plugs, etc.)
4. Position unit and align mounting holes with markings and install necessary screws.

---

NOTE: Remember to remove knock-outs before mounting the unit.

---

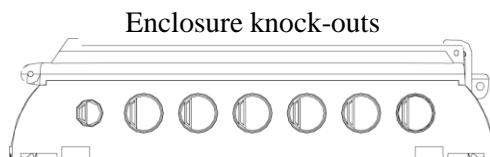

# PRODUCT SUBMITTAL

## 301AP Annunciator Panel



### WIRING DETAILS (PCB) 301AP

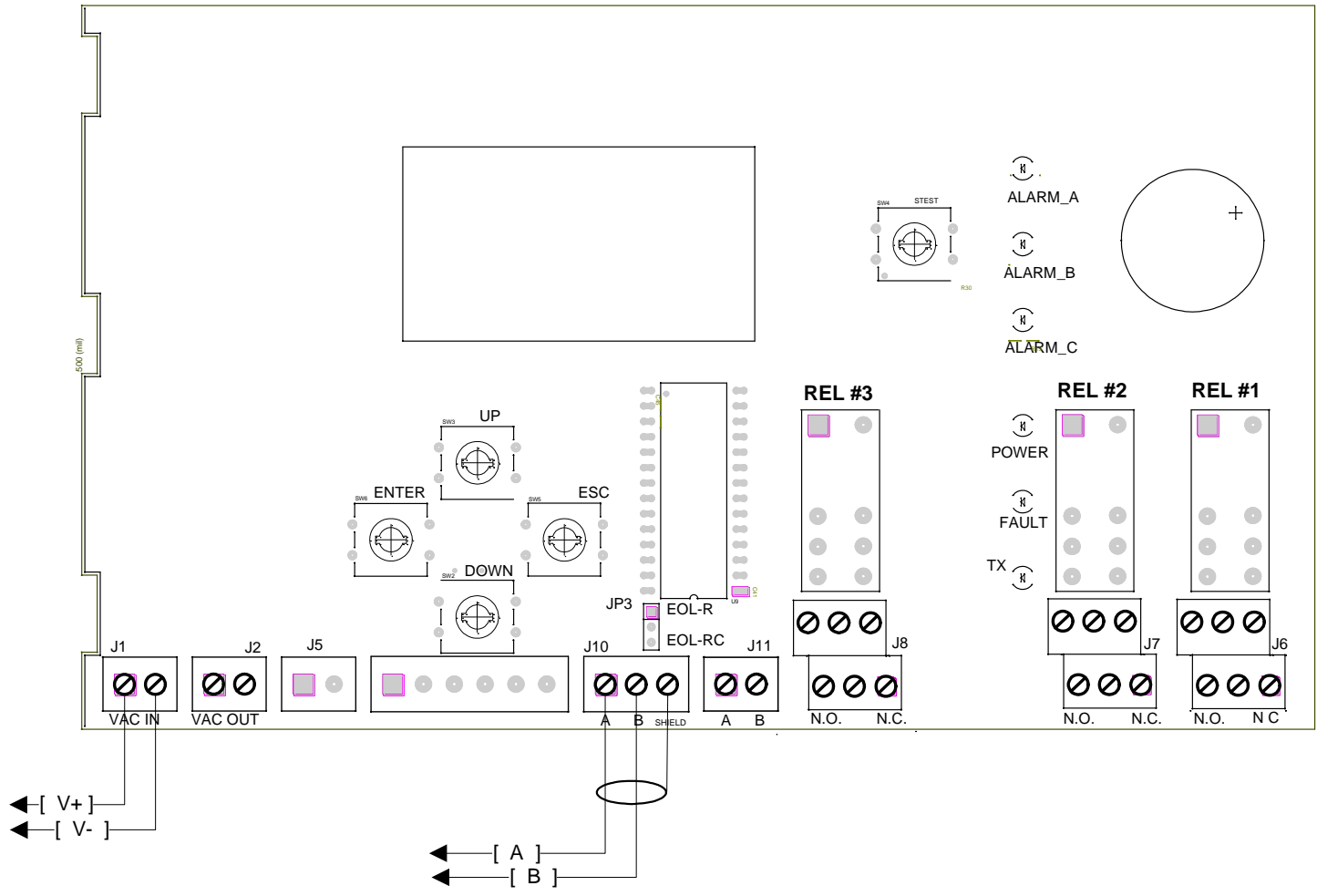

**RELAY OUTPUTS (J1-J8)**  
**5A, 30Vdc or 250Vac (resistive load)**

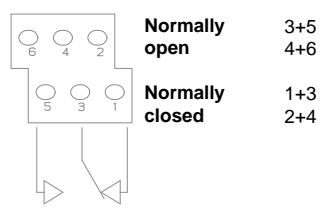

## 301AP Annunciator Panel

### WARRANTY AND LIMITS OF LIABILITY

Honeywell warrants to the original purchaser that its product, and the component parts thereof, will be free from defects in workmanship and materials for a period of one year from the date of purchase. Honeywell will, without any charge and at its option, repair or replace defective products or components upon their delivery to its Repair and Service Department. This warranty does not apply in the event of misuse or abuse of the product, or as a result of unauthorized alterations or repairs. Honeywell shall not be liable for any consequential damages, including, without limitation, damages resulting from loss of use. Every precaution for accuracy has been taken in the preparation of this manual. However, Honeywell neither assumes responsibility for any omissions or errors that may appear, nor liability for any damages that may result from the use of the products in accordance with the information contained in this manual.

To obtain warranty service, return the product, along with a complete description of the defect, transportation prepaid. Honeywell assumes no risk for damage in transit. Following warranty repair, the product will be returned to the buyer, transportation prepaid.