

870G

3 1/2 AUTO RANGE

DIGITAL DUAL DISPLAY AC CLAMP MULTIMETER

OPERATION MANUAL

This LCD Auto Range & Auto Power off Digital AC clamp multi meter is a portable, 3 1/2-digit multi meter. It is ideally suited for field, laboratory, shop and home applications.

1. SAFETY INFORMATION

The following safety information must be observed to insure maximum personal safety during the operation at this meter.

- 1) When measuring voltage ensure that instrument is not switched to the current range, resistance range, diode and continuity range, capacitance range or temperature range.
- 2) Use extreme care when measuring voltage above 50V, especially from sources where high energy is existed.
- 3) Avoid making connections to "live" circuits whenever possible.
- 4) Before making resistance measurements, diode or continuity test, capacitance test or temperature test, ensure that the circuit under test is de-energized.
- 5) Always ensure that the correct function and range is selected.
- 6) Extreme care should be taken when using the instrument to conjunction with a current transformer connected to the terminals if an open circuit occurs.
- 7) Ensure that the test leads and probes are in good condition with no damage to the insulation.
- 8) Take care not to exceed the over-load limits as given in the specifications.
- 9) Before opening the cover of the battery cabinet to replace batteries, disconnect the test leads from any external circuit, set the selector switch to "OFF" position.
- 10) Keep the fingers after the protection ring when measuring through the instrument lead.
- 11) Change the battery when the symbol appears to avoid incorrect data.

2. Panel Layout

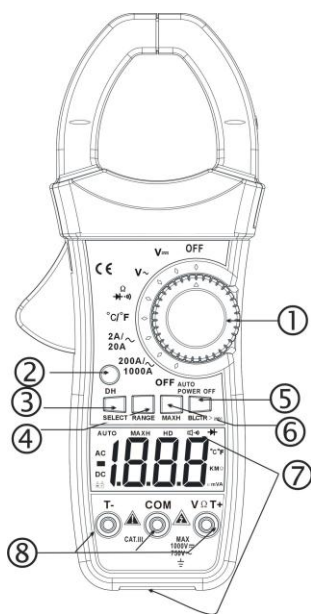

- 1) Rotary Switch: use this switch to select functions and ranges
- 2) D.HOLD key: In any range, push the key, the present display value will be locked and the "H D" symbol will appear, push it again to exit HOL and the "H D" symbol disappear.
- 3) SELECT key: This key work on the "Ω" range. Push the key to choose resistance, diode or continuity test.. Press "SELECT" in " °C/°F " rang , press direct for °C/ °F select.
- 4) RANGE key: Push the key to select manual mode, push it again to change the range, press the key for more than 2 seconds to go back auto range mode.
- 5) Back Light key: Press "BLCTR" button more than 2 seconds, the back light will light, press it more than 2 seconds again, the back light will light off.
- 6) MAXH key: Push MAXH key, will test max value for AC voltage or AC current(not a peak value).Push again, cancel this function.
- 7) LCD Display: LCD Dual Display, facilitates reads the data.

8) T+V Ω Hz Input Jack , COM Input Jack, T-Input Jack

2. SPECIFICATIONS

2.1 GENERAL SPECIFICATIONS

Display: 3 1/2 digit LCD with a max. reading of 1999.
 Range control: Auto range or manual range control.
 Polarity: Automatic negative polarity indication.
 Zero adjustment: Auto malic.
 Over range indication: Only the "OL" display.
 Low battery: The "BAT" is display when the battery voltage is below 2.4V.
 Auto Power Off: 15 minutes after stopping the switch or no push button, the meter automatically enter to power off mode. Push button or run switch, auto power off disable.
 Safety Standards: The meter is up to the standards of IEC1010 Double Insulation, Pollution Degree 2, Overvoltage Category III. Clamp opening size: 45mm.
 Operating Environment: Temperature 32~104° F(0~40°C), humidity<80%RH.
 Storage Environment: Temperature -4~140° F(-20~60°C),humidity<90%RH.
 Power supply: 9V Zinc-carbon battery.
 Dimension: 225(H)×90(W)×45(D)mm.
 Weight: Approx. 320g (including batteries).

2.2 ELECTRICAL SPECIFICATIONS

Accuracies are ±(% of reading +number in last digit) at 23±5°C, ≤75%RH.

2.2.1 DC Voltage

Range	Accuracy	Resolution
200mV	1.0% of rdg+15digits	0.1mV
2V	1.0% of rdg+8digits	1mV
20V		10mV
200V		100mV
1000V	1.0% of rdg+10 digits	1V

Overload protection: 1000V DC/750Vrms AC

Impedance: 10MΩ, More than100MΩ on 400mV scale

2.2.2 AC Voltage

Range	Accuracy	Resolution	Frequency
200mV	2.0% of rdg+15 digits	0.1mV	50~400Hz
2V	1.5% of rdg+10 digits	1mV	
20V		10mV	
200V		100mV	
750V	1.5% of rdg+15 digits	1V	50~100Hz

Average sensing, calibrated to rms of sine wave

Overload protection: 1000V DC/750Vrms AC

Impedance: 10MΩ, More than 100MΩ on 400mV scale

2.2.3 AC Current

Range	Accuracy	Resolution	Frequency
2A	4.0% of rdg+20 digits	1mA	50~60Hz
20A	2.5% of rdg+20 digits	0.01A	50~60Hz
200A		0.1A	
1000A	0~800	1A	50~60Hz
	800~1000		

Average sensing, calibrated to rms of sine wave

Overload protection: 1000Arms within 60 seconds

2.2.4 Resistance

Range	Accuracy	Resolution
200Ω	1.0% of rdg+25 digits	0.1Ω
2kΩ	1.0% of rdg+15 digits	1Ω
20kΩ		10Ω
200kΩ		100Ω
2MΩ		1kΩ
20MΩ	2.0% of rdg+20 digits	10kΩ



Overload protection: 250V DC/250Vrms AC

2.2.5 Temperature(NiCr-NiSi sensor)

Range	Accuracy	Resolution
°C/°F	-20~150°C -4~302°F	± (3°C+2)
	150~300°C 302~572°F	± (3% of rdg+2digits)
	300~1000°C 572~1800°F	± (3.5% of rdg+10digits)
		1°C/1°F

Overload protection: 36V DC/36Vrms AC

2.2.8 Diode and Audible continuity test

Range	Description	Test condition
	Display read approx. forward voltage of diode	Forward DC current approx. 0.4mA Reversed DC voltage approx. 1.5V
	Built-in buzzer sounds if resistance is less than 70Ω	Open circuit voltage approx. 0.5V

Overload protection: 250V DC/250Vrms AC

3. MEASURING INSTRUCTION

3.1 DC Voltage measurement

- 1) Connect the black test lead to "COM" socket and red test lead to the "+" socket.
- 2) Set the selector switch to desired "mV" or "V" position and connect the probes across the source or load under measurement.
- 3) Read the result from the LCD panel.

3.2 AC Voltage measurement

- 1) Connect the black test lead to "COM" socket and red test lead to the "+" socket.
- 2) Set the selector switch to desired "V~" position and connect the probes across the source or load under measurement.
- 3) Read the result from the LCD panel.

3.3 AC Current measurement

- 1) Set selector switch to desired "A~" position.
- 2) Open the clamp by pressing the jaw-opening handle and insert the cable (one cable only) to be measured into the jaw.
- 3) Close the clamp and get the reading from the LCD panel.

Note:

- a) Before this measurement, disconnect the test lead with the meter for safety.
- b) In same occasion that the reading is hard to read, push the D.HOLD button and read the result later.

3.4 Resistance measurement

- 1) Connect the black test lead to "COM" socket and red test lead to the "+" socket.
- 2) Set the selector switch to desired "Ω" position, the present function is resistance measurement, if it is other function, push the SELECT to select resistance measurement.
- 3) Connect the probes across circuit to be tested.
- 4) Read the result from the LCD panel.

Caution: Ensure that the circuit to be tested is "dead". Max. input over-load: 250V rms < 10sec

3.5 Diode test

- 1) Connect the black test lead to "COM" socket and red test lead to the "+" socket.
- 2) Set the selector switch to "Ω" position.
- 3) Push "SELECT" to select diode test.
- 4) Connect the black and red test probe to the cathode (-) and anode (+) ends of diode to be tested respectively, read the forward voltage drop (junction) value from the display. If reverse connected the probes to diode, display shows over-load.

Caution: Ensure that the circuit to be tested is "dead".

Max .input over-load: 250V rms < 10sec

3.6 Audible continuity test

- 1) Connect the black test lead to "COM" socket and red test lead to the "+" socket.
- 2) Set the selector switch to "Ω" position.
- 3) Push "SELECT" to select audible continuity test.
- 4) Connect the probes across circuit to be tested, the beeper sounds continuously if the resistance is less than approx. 50Ω.

Caution: Ensure that the circuit to be tested is "dead". Max .input over-load: 250V rms < 10sec

3.9 Temperature measurement

- 1) Connect the black test lead of the sensor to "COM" socket and the red test lead to the "+" socket.
- 2) Set the selector switch to "°C" position.
- 3) Put the sensor probe into the temperature field under measurement.
- 4) Read the result from the LCD panel.

Max .input over-load: 250V rms < 10sec

A. The temperature function shows the random number at ordinary times, must insert the thermocouple in temperature test hole while examining temperature.

B. This meter inclosure WRNM-010 type contact thermocouple limit temperature is 250 °C (300 °C shortly) ;

C. Please don't change the thermocouple at will , otherwise we

can't guarantee to measure accuracy ;

D. Please don't importing the voltage in the temperature function.

3.10 Auto/Manual Range Control

The auto range mode is a convenient function, but it might be faster to manually set the range when you measure values that you know to be within a certain range .To select manual range control, repeatedly press "RANGE" until the display shows the desired range. The range steps upward as you press "RANGE". But when you press "RANGE" for more than 2 seconds, then it can go to auto range mode. In Hz/Duty and capacitance measurement, it can not select manual range mode.

Caution: While suing the manual range control, if "OL" appears on the display and you hear an intermittent tone, immediately set RANGE to a higher range.

3.7 Relative measurement

Press "REL", you can measure the relative value and "▲" appears on the display, the auto range mode be changed to manual range mode. Press again, return to the previous condition and "▲" disappears, but you can not go back to auto range mode. In Hz/Duty measurement, you can not measure the relative value.

4. CARE AND MAINTENANCE

4.1 CARING FOR YOUR MULTIMETER

Your Digital Multi meter is an example of superior design and craftsmanship. The following suggestions will help you care for the multi meter so you can enjoy it for years.

- 1) Keep the multi meter dry. If it gets wet, wipe it dry immediately. Liquids can contain minerals that can corrode electronic circuits.
- 2) Use and store the multi meter only in normal temperature environments. Temperature extremes can shorten the life of electronic devices, damage batteries and distort or melt plastic parts.

3) Handle the multi meter gently and carefully. Dropping it can damage the circuit boards and cause and can accuse the multi meter to work improperly.

4) When take current measurement, keep the cable at the center of the clamp will get more accurate test result.

5) Keep the multi meter away from dust and dirt, which can cause premature wear of parts.

6) Wipe the multi meter with a damp cloth occasionally to keep it looking new. Do not use harsh chemicals, cleaning solvents, or strong detergents to clean the multi meter.

7) Use only fresh batteries of the required size and type. Always remove old or weak batteries. They can leak chemicals that destroy electronic circuits.

8) Please take out the battery when not using for a long time.

4.2 9Volt battery replacement

1) Ensure the instrument is not connected to any external circuit. Set the selector switch to "OFF" position and remove the test leads from the terminals.

2) Open the cover of the battery cabinet by a screwdriver.

3) Replace the old batteries with the same type batteries.

4) Close the battery cabinet cover and fasten the screw.

Above picture and content just for your reference. Please be subject to the actual products if anything different or updated. Please pardon for not informing in advance.