



EC-PU4

Processor unit with 4 communication ports

The central processor unit in the EXOclever controller series. Equipped with three serial ports and one TCP/IP port.

EXOclever

EXOclever is a series of freely programmable controllers of modular design, which makes it easy to increase the capacity and add more functions.

EXOclever is programmed from EXOdesigner and visualised in EXOscada.

Areas of application

EXOclever is primarily intended for use in installations with a large number of I/O:s and high demands on communication and adaptability.

EXOclever can be used either as a stand-alone unit or together with other EXO products as part of a larger automation system.

In large automation systems, EXOclever is the basis, with EXOcompact and EXOdos as good supplements.

Installation

EXOclever units can be mounted in two ways. Besides being mounted on their backside, they can also be stacked on the short side with a high packing density as a result.



Short facts about EC-PU4

- Scalable and flexible units
- The ideal solution for large systems
- Future proof technology
- Based on EXOrealC
- Unique solution for space-saving mounting
- Compatible with EXOflex and other products in the EXO range

The EXOclever unit uses push-in connectors for easy and fast cable installation. The push-in connectors have integrated test holes in each terminal for easy test measurements.



Status indication

Status indication is shown by LEDs on the side of the unit which makes it easy to see if there is a connection problem, if data is being transferred on the different ports or if the battery needs to be changed.

Communication ports**Port 1-3**

Three identical isolated EXOline RS485 ports with E-signal, intended for communication with peripheral units and other controllers.

EFX

The EFX port is the communication channel between the processor and external PIFA housings. PIFA housings communicate with EXOreal in the processor housing via the so-called EFX-channel. EFX is RS485-based communication, which is only intended for use between PIFA units and EXOreal in the proximity.

EC-PU4 holds the role as EFX master.

DSP (External Display)

The DSP port is used to connect an external display. The port is a non-isolated RS485 port with a 4P4C unshielded modular connector.

Since the port is unshielded and non-isolated, care must be taken if not using Regin standard attached display cable kit.

TCP/IP

The TCP/IP port connects to a standard computer network and is used to communicate between the SCADA system and the controller or between controllers.

Built-in battery

The processor unit contains a battery that preserves the application variables and keeps the hardware clock running when it has no power.

The battery is easy to replace. A backup capacitor saves the memory and keeps the clock running for at least 10 minutes after the battery has been removed.

Technical data

Supply voltage	24 V AC or 24 V DC
Tolerance	18...26 V AC / 22...30 V DC
Power consumption	10 VA / 5 W
Dimensions (WxHxD, incl. terminals)	140 x 136 x 40 mm
Mounting	DIN-rail
Protection class	IP20
Real-time clock (RTC)	max ±20 sec./month
Operating system	EXOreal C
Application SRAM memory	768 kB available for user applications
Application flash memory (TCP/IP)	~7 MB available for user applications



EMC: This product conforms to the requirements of the EMC Directive 2014/30/EU through product standards EN 61000-6-2:2005 and EN 61000-6-3:2007.

RoHS: This product conforms to the Directive 2011/65/EU of the European Parliament and of the council.

Battery

Type	Replacable Lithium cell, CR2032
Battery backup of RAM, RTC	5 years
Battery monitoring	System status LED + Software accessible

Operation

Ambient temperature	0...55°C
Humidity (non-condensing)	Max. 95%

Storage

Ambient temperature	-20...+70°C
Humidity (non-condensing)	Max. 95%

Communication**Port I-3**

Type	RS485
Built-in protocol	EXOline
Other protocols	contact Regin
Control signal, RS485	E
Speed	configurable, max 76800 bps
Standard Speed	9600 bps
Galvanic isolation, common mode voltages	max. 150 V
Max communication distance	1200 m (depending on communication speed)

EFX port

Type	RS485
Communication speed	115200 bps
Max communication distance	300 m
Galvanic isolation, common mode voltages	No

TCP/IP port

Type	10Base-T/100Base-TX auto-negotiation built-in protocol
EXOreal 3.4 or later	EXOlineTCP Slave, EXOlineTCP Master, Modbus TCP Slave, BACnet/IP, HTTP, SMTP
Auto MDIX	Yes
Fast connector	shielded RJ45
Supported standards	IEEE 802.3u and IEEE 802.3x full-duplex flow control
Cable length (max)	100 m (min CAT 5e)

Wiring

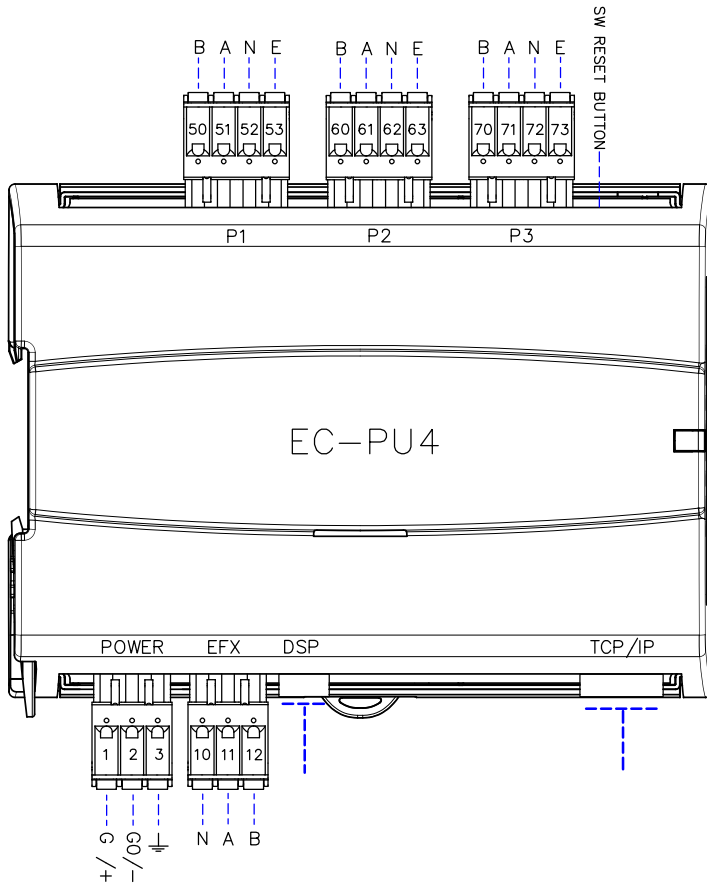

Pinout P1-P3 ports

Pin	Signal	Signal description
50/60/70	B	Non-inverted (+) data signal line
51/61/71	A	Inverted (-) data signal line
52/62/72	N	Cable screen connection (must be earthed at one point since isolated from the system)
53/63/73	E	Control signal, RS485

Pinout POWER port

Pin	Signal	Signal description
1	G/+	Power input, 24 V AC or 24 V DC (+) at power supply
2	G0/-	System ground, 0 V connection (-) at power supply
3	⏏	EMI earth, connect to earth rail

Pinout EFX port

Pin	Signal	Signal description
10	N	Cable screen earth
11	A	Inverted (-) data signal line
12	B	Non-inverted (+) data signal line

Dimensions

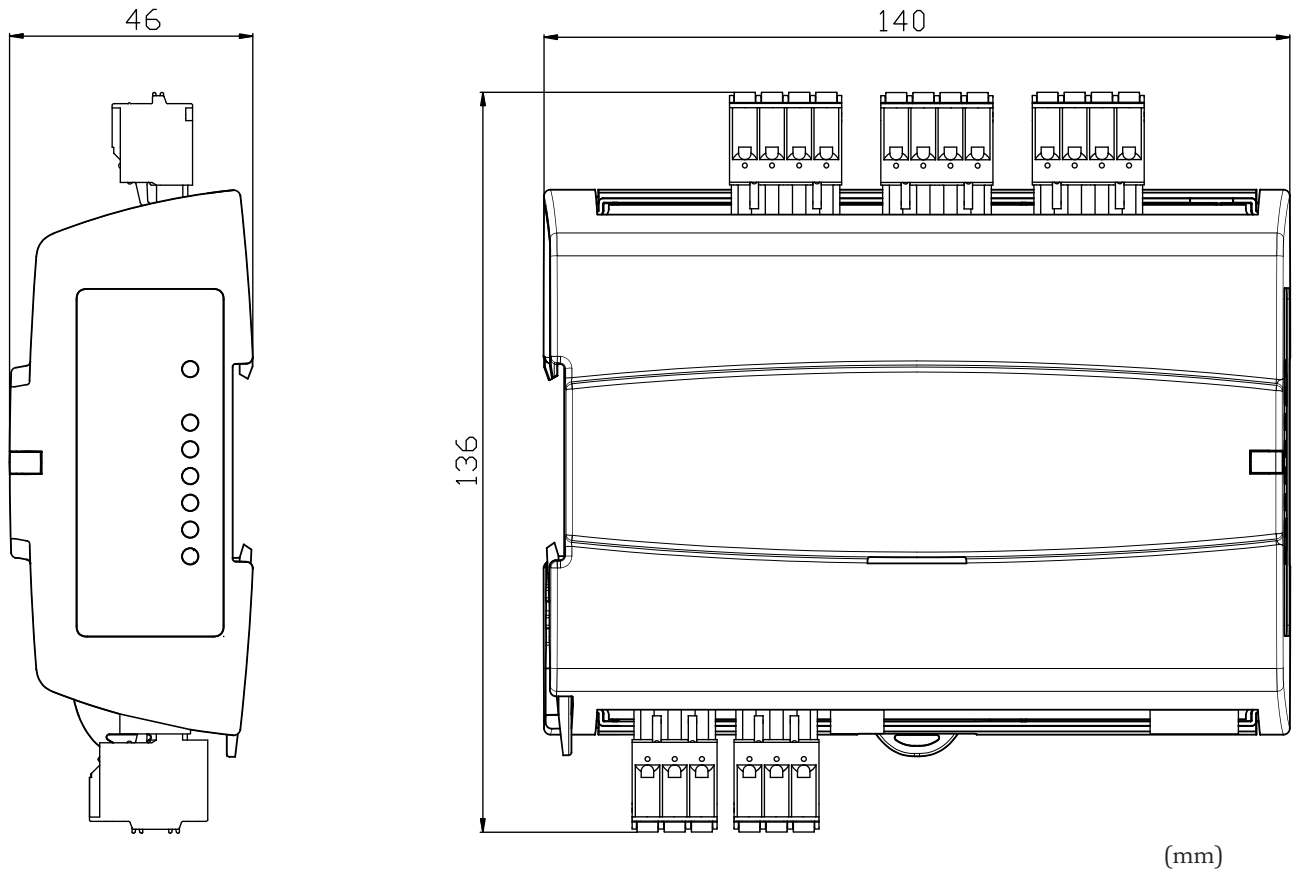

Product documentation

Document	Type
Manual EXOclever	Manual for EXOclever

The manual can be downloaded from Regin's FTP server. The FTP is intended for our system customers who need to share files with us, e.g. at technical support. Contact one of our sales engineers to get access to the FTP server.