

Synco™ 700

Universal Modules

RMZ78...

Extension modules for use with controls of the Synco™ 700 family.

Use

For heating, ventilation, air conditioning and chilled water plant equipped with controls of the Synco™ 700 family.

Functions

The universal modules are designed to increase the number of inputs and outputs of Synco™ 700 controls, thus providing additional control and monitoring functions.

Type summary

Type reference	Number of universal inputs	Number of analog outputs	Number of relay outputs	
			N.O. contacts	Changeover contacts
RMZ785	8	–	–	–
RMZ787	4	0	3	1
RMZ788	4	2	1	1
RMZ789	6	2	2	2

Ordering

When ordering, please give name and type reference, for example:

Universal module **RMZ785**

The module connector listed under "Accessories" must be ordered as a separate item, if required.

Equipment combinations

The universal modules must be used in connection with controls of the Synco™ 700 family. At present, the following combinations are possible:

Type of Synco device	RMZ785	RMZ787	RMZ788	RMZ789
Universal controller RMU7...	•	•	•	–
Heating controller RMH760	–	•	•	–
Boiler sequence controller RMK770	•	•	•	•
Control center RMB795	•	•	–	–
Control and monitoring unit RMS705	•	•	–	–

For details of these Synco devices, refer to Product Range Description S3110 or the document of the selected application.

Product documentation

Name	Classification number
Mounting Instructions	M3110
Product Range Description	S3110
Application catalog for Synco™ 700 ventilation / air conditioning plant	
Declaration of Conformity (CE)	T3110
Environmental Declaration	E3110...02

Technical design

The RMZ78... universal modules complement the range of Synco™ 700 controls. They cannot be operated autonomously.

The universal modules are incorporated into the Synco™ 700 controls in the basic configuration. All settings associated with the universal modules are made on the relevant Synco™ 700 control.

The signals from sensors, signal sources, etc., are delivered to the Synco™ 700 device for handling. The control signals and commands generated by the control are fed back to the respective universal module from where they are passed on to the connected actuating devices.

The universal module is powered by the relevant Synco™ 700 control, which also identifies and monitors the module.

Mechanical design

Basic design

In terms of mechanical design, the extension modules are identical with the Synco™ 700 controls. No wiring is required between the individual modules or between module and controller. The electrical connections are established by attaching the module to the control.

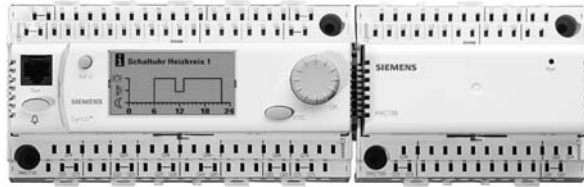

Synco™ 700 controller with attached RMZ78... module

Operation

The extension modules have no setting and operating elements. Operation is accomplished with the help of the RMZ790 or RMZ791 operator unit. Exception is the LED, which indicates the module's operating state.

Operating, display and connecting elements

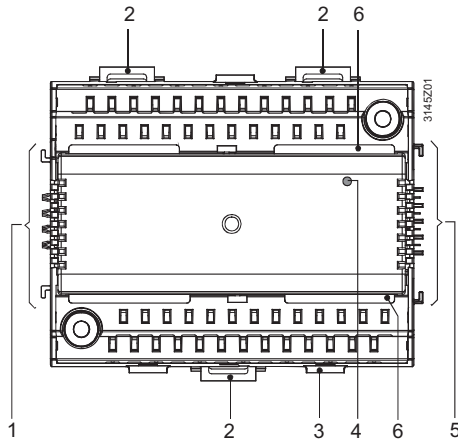

- 1 Connecting elements for Synco™ 700 control or another extension module
- 2 Catch for fitting the module to a top hat rail
- 3 Fixing facility for the cable tie (cable strain relief)
- 4 LED (green) for indicating the operating state
- 5 Connecting elements for another extension module
- 6 Rest for the terminal cover

Accessories

Accessory	Type reference	Data Sheet
Module connector	RMZ780	N3138

Engineering notes

- Fuses, switches, wiring and earthing must be in compliance with local safety regulations
- Sensor cables should not be run parallel to mains-carrying cables powering loads such as fans, actuators and pumps

Mounting and installation notes

- The modules are designed for:
 - Mounting in a standard cabinet conforming to DIN 43 880
 - Wall mounting on an existing top hat rail (EN 50 022-35x7.5)
 - Wall mounting with 2 fixing screws
 - Flush panel mounting
- Not permitted are wet or damp spaces; the permissible ambient temperatures must be observed
- Disconnected the system from power supply prior to mounting and installing the module

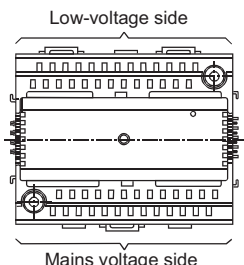

- The module must be fitted on the right hand side of the Synco™ 700 control in the correct order, in accordance with the internal configuration
- The extension modules need not be wired, neither between themselves nor to the Synco™ 700 control. The electrical connections are made automatically when attaching the modules. If it is not possible to arrange all extension modules side by side, the first of the detached modules must be connected to the previous module or the Synco™ 700 control by using the RMZ780 module connector. In that case, the cumulated cable length must not exceed 10 meters
- The connection terminals for protective extra low-voltage are located in the upper half of the module, those for mains voltage (actuators and pumps) at the bottom
- Only one solid or stranded wire may be connected to each terminal (spring cage terminals). For fixing the wires, the cables must be stripped by 7 to 8 mm. To introduce the wires into the spring cage terminals, or to remove them, a screw driver size 0 or 1 is required. Cable strain relief can be ensured with the help of the lugs for cable ties
- The module mounted on a top hat rail together with other modules can only be removed from the rail after the 3 catches have been brought into their release and hold position (audible "click"). After removal, the catches must be pushed back into their snap-on position
- The module is supplied complete with Mounting Instructions

Commissioning notes

During the commissioning process, the outputs are in a defined off state.

Disposal notes

Larger plastic parts carry material identifications to ISO / DIS 11 469 to facilitate environment-compatible disposal.

Technical data

Power supply	Rated voltage	AC 24 V ±20 % (via the controller)
	Power consumption	3 VA
Analog inputs (X...)	Sensors	
	Passive	1 or 2 LG-Ni 1000, T1, Pt 1000
	Active	DC 0...10 V
	Signal sources	
	Passive	0...2500 Ω
	Active	DC 0...10 V
Digital inputs (X...) (status and counting values)	Contact sensing	
	Voltage	DC 15 V
	Current	5 mA
	Requirements for the status and impulse contacts	
	Signal coupling	potential-free
	Type of contact	maintained or impulse contacts
	Insulating strength against mains potential	AC 3750 V to EN 60 730
	Perm. resistance	
	Contacts closed	max. 200 Ω
	Contacts open	min. 50 kΩ

Positioning outputs (Y1, Y2)	Output voltage	DC 0...10 V
	Output current	±1 mA
	Max. load	continuous short-circuit
 Switching outputs (Q...)	External supply line fusing	
	Non-renewable fuse (slow)	max. 10 A
	Automatic line cutout	max. 13 A
	Release characteristic	B, C, D to EN 60 898
	Cable length	max. 300 m
	Relay contact data	
	Switching voltage	max. AC 265 V / min. AC 19 V
	AC current	max. 4 A res., 3 A ind. (cos φ = 0.6)
	At 250 V	min. 5 mA
	At 19 V	min. 20 mA
	Switch-on current	max. 10 A (1 s)
	Contact life at AC 250 V	guide values:
	At 0.1 A res.	2×10 ⁷ cycles
	N.O. contact at 0.5 A res.	4×10 ⁶ cycles
	Changeover contact at 0.5 A res.	2×10 ⁶ cycles
	N.O. contact at 4 A res.	3×10 ⁵ cycles
	Changeover contact at 4 A res.	1×10 ⁵ cycles
Reduction factor at ind. (cos φ = 0,6)	0.85	
Insulating strength		
Between relay contacts and system electronics (reinforced insulation)	AC 3750 V, to EN 60 730-1	
Between neighboring relay contacts (operational insulation) Q1 ↔ Q2; Q3 ↔ Q4	AC 1250 V, to EN 60 730-1	
Between relay groups (reinforced insulation) [Q1, Q2] ↔ [Q3, Q4/Q5]	AC 3750 V, to EN 60 730-1	
Power supply external devices (G1)	Voltage	AC 24 V
	Current	max. 4 A
Electrical connections	Connection terminals	spring cage terminals
	For solid wires	0.6 mm dia...2.5 mm ²
	For stranded wires without ferules	0.25...2.5 mm ²
	For stranded wires with ferules	0.25...1.5 mm ²
Protection	Degree of protection of housing to IEC 60 529	IP20 (when mounted)
	Safety class to EN 60 730	device suited for use with equipment of safety class II
Environmental conditions	Operation to	IEC 60 721-3-3
	Climatic conditions	class 3K5
	Temperature (housing with electronics)	0...50 °C
	Humidity	5...95 % r.h. (noncondensing)
	Mechanical conditions	class 3M2
	Transport to	IEC 60 721-3-2
	Climatic conditions	class 2K3
	Temperature	-25...+70 °C
	Humidity	<95 % r.h.
	Mechanical conditions	class 2M2

Classifications to EN 60 730	Mode of operation, automatic controls	type 1B
	Degree of contamination, controls environment	2
	Software class	A
	Rated surge voltage	4000 V
	Temperature for ball-test of housing	125 °C
Materials and colors	Terminal base	Polycarbonate, RAL 7035 (light-grey)
	Insert	Polycarbonate, RAL 7035 (light-grey)
	Packaging	corrugated cardboard
Standards	Product safety	
	Automatic electrical controls for household and similar use	EN 60 730-1
	Special requirements for energy controllers	EN 60 730-2-11
	Electromagnetic compatibility	
	For use in industrial and domestic environments	
	Immunity	EN 60730-1
	Emissions	EN 60730-1
	CE conformity to	
	EMC directive	2004/108/EC
	Low-voltage directive	2006/95 EC
	✓ conformity to	
Australian EMC Framework	Radio communication act 1992	
Radio Interference Emission Standard	AS/NZS 3548	
Environmental compatibility		
The product environmental declaration	ISO 14001 (Environment)	
CE1E3113 contains data on environmentally compatible product design and assessments (RoHS compliance, materials composition, packaging, environmental benefit, disposal)	ISO 9001 (Quality) SN 36350 (Environmentally compatible products) RL 2002/95/EG (RoHS)	
Weight	RMZ785 (excl. packaging)	0.25 kg
	RMZ787 (excl. packaging)	0.30 kg
	RMZ788 (excl. packaging)	0.28 kg
	RMZ789 (excl. packaging)	0.31 kg

Internal diagrams

RMZ785



RMZ787

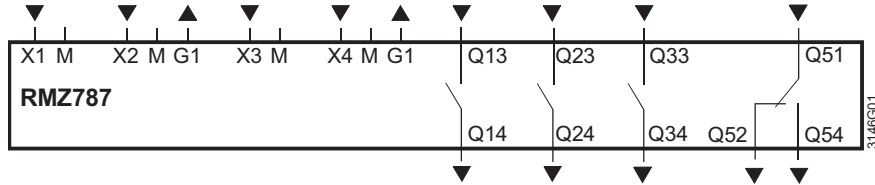

RMZ788

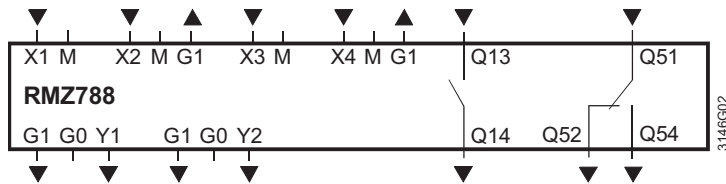

RMZ789

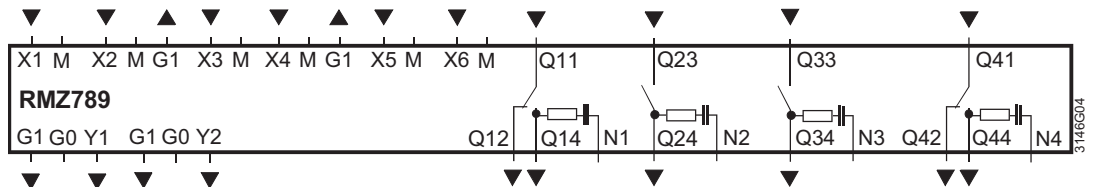

- G0 System neutral for signal outputs
- G1 Output voltage AC 24 V for powering external active devices
- M Measuring neutral for signal inputs
- N... Radio interference suppression for 3-position actuators
- Q... Potential-free relay inputs and outputs for AC 24...230 V
- X... Universal signal inputs for LG-Ni 1000, 2x LG-Ni 1000 (averaging), T1, Pt 1000, DC 0...10 V, 0...1000 Ω (setpoint), 1000...1175 Ω (rel. setpoint), contact sensing (potential-free)
- Y... Control or status outputs DC 0...10 V

Notes

- Each terminal (cage terminal) can accommodate only 1 solid wire or 1 stranded wire
- Double terminals are internally interconnected

Dimensions

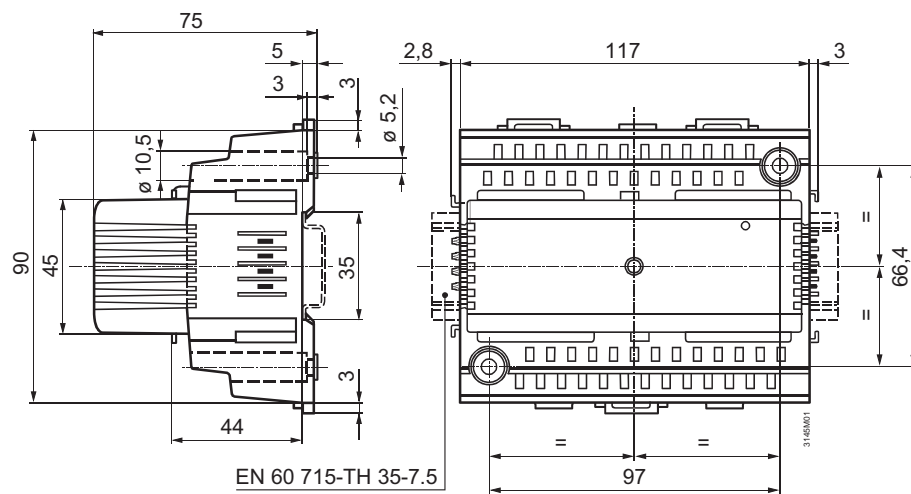

Dimensions in mm