



SQL35.00 / SQL85.00



SQL36E..

ACVATIX™

Electromotoric actuators

SQL35.00
SQL85.00
SQL36E..

VKF46.., VKF46..TS butterfly valves

- **SQL35.00, SQL36E..** operating voltage AC 230 V, 3-position control signal
- **SQL85.00** operating voltage AC 24 V, 3-position control signal
- **Nominal angle of rotation 90°**
- **Auxiliary switch and potentiometer for extra functions**
- **Manual adjuster and position indicator**
- **SQL36E.. built-in heating element to avoid condensation**
- **SQL36E.. compatible with EN ISO 5211 flanges**
- **SQL36E.. variable positioning time with SEZ31.1 auxiliary module**

Use

For operation of VKF41.., VKF46.. and VKF46..TS butterfly valves as control and shutoff valves in heating, ventilation and air conditioning plants.

Type summary

Type	Operating voltage	Positioning signal	Positioning time for 90° at 50 Hz		Torque	Flange connection EN 5211
			without SEZ31.1	with SEZ31.1		
SQL35.00	AC 230 V	3-position	125 s		20 Nm	
SQL85.00	AC 24 V					
SQL36E50F04	AC 230 V		25 s	30...180 s	40 Nm	F04
SQL36E50F05						F05
SQL36E65			6 s	60...360 s	100 Nm	F07
SQL36E110			12 s	120...720 s	400 Nm	F10
SQL36E160			24 s		1200 Nm	¹⁾

¹⁾ EN 5211 F12 / F16 flange connections for third-party butterfly valves are available on request.

Accessories

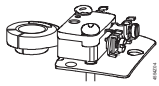
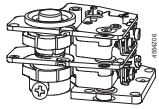
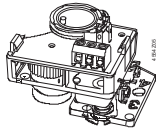
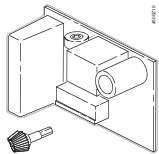
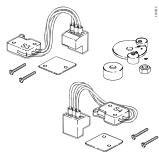
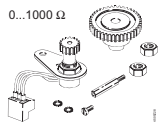
Type		Description	For actuators	Mounting position
ASC9.5		Auxiliary switch	SQL35.00 SQL85.00	1 x ASC9.5 or 1 x ASC9.4 or 1 x ASZ7.4 (only one accessory at a time can be mounted)
ASC9.4		Double auxiliary switch		
ASZ7.4		Auxiliary switch and potentiometer 1000 Ω		
SEZ31.1		Auxiliary module for variable positioning time (refer to «Function/mechanical design», page 4)	SQL36E65 SQL36E110 SQL36E160	1 x SEZ31.1 and 1 x ASC36 and 1 x ASZ36
ASC36		Double auxiliary switch	SQL36E50F04 SQL36E50F05 SQL36E65	
ASZ36		Potentiometer 1000 Ω	SQL36E110 SQL36E160	

Ordering

Example:

Type	Stock no.	Description	Quantity
SQL35.00	SQL35.00	Electromotoric actuator	1
ASK35.1	ASK35.1	Mounting set	1
ASZ7.4	ASZ7.4	Potentiometer 1000 Ω	1

The actuator, butterfly valve, mounting set and any accessories must be ordered separately.

Delivery

The actuator, butterfly valve, mounting set and accessories are packed separately and delivered as individual items.

Spare parts, rev.-no.

Overview see page 13.

Equipment combinations

Butterfly valves	Electromotoric actuators						Data sheet
	SQL35.00 SQL85.00	SQL36E50F04	SQL36E50F05	SQL36E65	SQL36E110	SQL36E160	
VKF46.40	ASK35.1	direct mounting					N4136
VKF46.50	ASK35.1	direct mounting					
VKF46.65	ASK35.1	direct mounting					
VKF46.80	ASK35.2		direct mounting				
VKF46.100	ASK35.2		direct mounting				
VKF46.125	ASK35.2		direct mounting				
VKF46.150				direct mounting			
VKF46.200				direct mounting			
VKF46.250					direct mounting		
VKF46.300					direct mounting		
VKF46.350					direct mounting		
VKF46.400					direct mounting		
VKF46.450						direct mounting	
VKF46.500						direct mounting	
VKF46.600						direct mounting	
VKF46.350TS						direct mounting	N4136
VKF46.400TS						direct mounting	
VKF46.450TS						direct mounting	
VKF46.500TS						direct mounting	
VKF46.600TS						direct mounting	
VKF41.150...200	ASK35						N4131
VKF45.40...125 ¹⁾	ASK35						N4135
VKF45.150...200 ¹⁾	ASK35			direct mounting			

¹⁾ VKF45.. butterfly valves were replaced by VKF46.. butterfly valves in the year 2000. For actuator retrofitting on installed butterfly valves, replacement of actuators or ASK35:

- VKF45.40..125: Use SQL35.00 / SQL85.00 actuators and ASK35
- VKF45.150...200: Mounting of SQL36E65 actuator recommended

Function / mechanical design

The actuator is driven by a 3-position signal from the controller and generates a rotary motion which is transferred via a driver to the valve.

SQL35.00 SQL85.00

These electromotoric actuators require no maintenance. They have a reversible synchronous motor and reduction gears with self-lubricating sinter bearings.

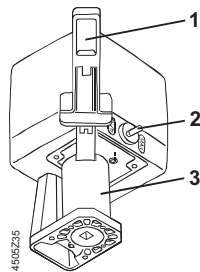

- 1 Manual lever
- 2 Rotary «AUTO» / «MAN» selector
- 3 Yoke

When the selector is set to «MAN», the butterfly valve can be operated with a manual lever. For manual operation, the angle of rotation is mechanically limited by an end stop.

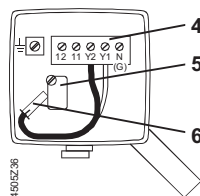

- 4 Terminal strip
- 5 Double end switch (always factory-installed), non-adjustable
- 6 Plug for reversing direction of rotation

SQL36E...

These electromotoric actuators require no maintenance. They have a reversible asynchronous motor which drives the main shaft via spur gears and a self-locking worm

gear, which accommodates the rectangular shaft of the butterfly valve. The worm shaft is fitted with a direct-acting manual adjuster.

The actuators are supplied with a 90° angle of rotation suitable for use with Siemens butterfly valves. During automatic operation, rotation is limited by two built-in non-adjustable end-switches.

The direction of rotation of the actuator can be reversed (refer to «Commissioning»). To prevent the temperature inside the housing from falling below the dewpoint temperature, the actuators are supplied with a built-in heating element (AC 230 V, power consumption 5 W).

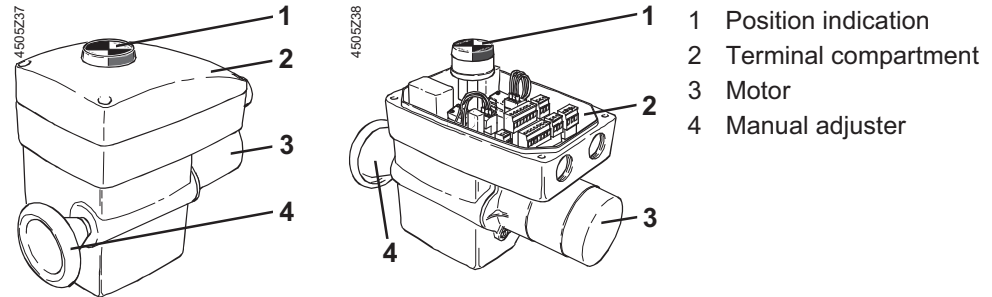

Accessory for
SQL36E65
SQL36E110
SQL36E160

SEZ31.1

Auxiliary module

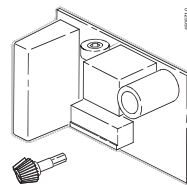

In the presence of a 3-position signal, the auxiliary module pulses the actuator. The output shaft rotates by approximately 2° with each pulse. The pulse-to-pause ratio is continuously adjustable and can therefore be used to achieve longer running times for an angle of rotation of 90° (refer to «Commissioning»).

Engineering notes

Electrical installation

The actuators must be electrically connected in accordance with local regulations and with the connection diagrams.



Regulations and requirements to ensure the safety of people and property must be observed at all times.

Mounting notes

Overview of
Mounting Instructions

Type	Mounting Instructions	
SQL35.00/SQL85.00	M4290.4	74 319 0215 0
ASK35..	M4290.4	74 319 0215 0
ASK35	M4135.1	4 319 5556 0
ASC9.4	G4506.5	4 319 5537 0
ASC9.5	G4506.7	4 319 5557 0
ASZ7.4	G4506.6	4 319 5538 0

Type	Mounting Instructions	
SQL36E..	M4505.1	74 319 0440 0
ASC36	M4505.3	74 319 0442 0
ASZ36	M4505.2	74 319 0441 0
SEZ31.1	M4505.4	74 319 0443 0

SQL35.00 / SQL85.00

These actuators must be used with the following mounting set:

- ASK35.1 or ASK35.2 for VKF46.. butterfly valves
- ASK35 for VKF41.150 and VKF41.200 butterfly valves

SQL36E...

These actuators are mounted directly on type VKF46... butterfly valves. The butterfly valves have to be closed during installation.

In case of unsteady ambient temperatures connect the built-in heating element to avoid condensation.

The valve and actuator can be assembled straightforwardly on site. There is no need for special tools.

Orientation

SQL36E..

Any

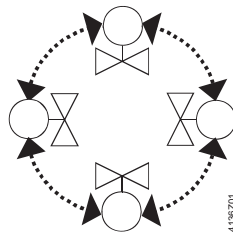

SQL35.., SQL85..

Upright to horizontal

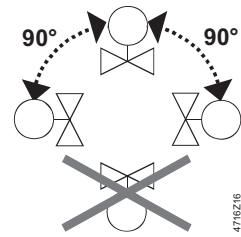

Commissioning notes

When commissioning the complete motorized valve consisting of actuator, mounting set and butterfly valve, always check the wiring and test the functions. This also applies to any additional components fitted, e.g. auxiliary switch, potentiometer or auxiliary module (variable positioning time).

VKF41.. or VKF46... butterfly valves can only be commissioned with a SQL35.00 / SQL85.00 or SQL36E.. actuator or with an ASK46... manual adjuster fitted.

Warning

To avoid pressure shocks on the butterfly, the VKF46.. must be driven to its fully open position (either manually or via positioning signal Y1) prior to activating the pump(s).

The flow rate is adjusted either by driving the electric actuators as required, or by operating the manual adjuster.

When using a SEZ31.1 auxiliary module set the desired positioning time:

SQL36E65: 30...180 s

SQL36E110: 60...360 s

SQL36E160: 120...720 s

Operating mode

SQL35.00 / SQL85.00



«AUTO» = automatic operation

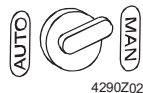

«MAN» = manual operation

SQL36E...

In the case of the SQL36E..., the manual adjuster is always engaged and cannot be mechanically disconnected.

Direction of rotation

SQL35.00 / SQL85.00

The actuators are factory-set to rotate in clockwise direction for opening (as seen from the cover).

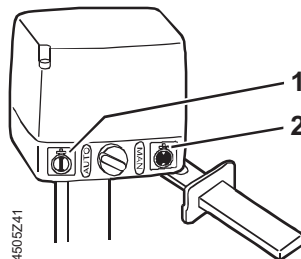

Position indication

The adhesive labels supplied must be applied during assembly.

- 1 Butterfly valve in «OPEN» position
- 2 Butterfly valve in «CLOSED» position

SQL36E...

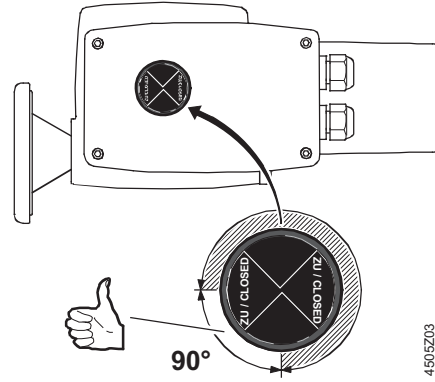

The direction of rotation of these types of actuators for opening is counterclockwise.

Reversing the direction of rotation
SQL35.00 / SQL85.00

The direction of rotation can be reversed by repositioning a connector located under the cover. The wiring for the OPEN and CLOSE control signal is not affected

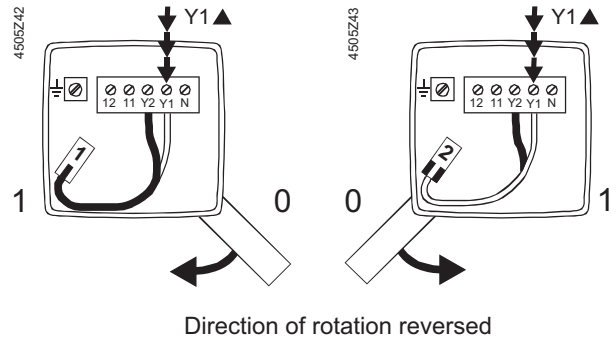

SQL36E...

If the direction of rotation needs reversing, simply change the connections Y1/Y2.

Setting the angle of rotation

The 0...90° angle of rotation for the end switches is factory-set and. They cannot be adjusted. The potential-free auxiliary switches have adjustable switching points.

Control

Every actuator must be driven by a dedicated controller (refer to «Connection diagrams»).

Maintenance

Caution

The actuators and butterfly valves require no maintenance.

Before performing any service work on the valve or actuator:

- Switch off the pump and power supply
- Close the main shut-off valves in the pipework
- Release pressure in the pipes and allow them to cool down completely

If necessary, disconnect electrical connections from terminals.

The valve must be re-commissioned only with the manual adjuster or the actuator correctly assembled.

Disposal



The actuator contains electrical and electronic components and must not be disposed of together with domestic waste.

Legislation may demand special handling of certain components, or it may be sensible from an ecological point of view.

Current local legislation must be observed.

Warranty

The technical data given for these applications is valid only in conjunction with the Siemens butterfly valves as detailed under «Equipment combinations». The use of third-party valves other than those recommended by Siemens invalidates the warranty.

Technical data

		SQL35.00	SQL85.00	SQL36E50..	SQL36E65	SQL36E110	SQL36E160
Power supply	Operating voltage	AC 230 V ±15 %	AC 24 V ±20 %	AC 230 V -5 / +10 %			
	Frequency	50 / 60 Hz					
	Power consumption ¹⁾	6.5 VA		35 VA	160 VA	235 VA	
Control	Positioning signal	3-position					
	Parallel operation	parallel operation of several actuators not possible					
Operating data	Positioning time for 90°						
	at 50 Hz	125 s	25 s	6 s ²⁾	12 s ²⁾	24 s ²⁾	
	at 60 Hz	105 s	20 s	5 s	10 s	20 s	
	Angle of rotation	90° ± 1° (factory setting)					
	Torque ¹⁾	20 Nm	40 Nm	100 Nm	400 Nm	1200 Nm	
	End switch	Switching capacity AC 250 V, 3 A resistive, 1.5 A inductive Switching differential approx. 1° End position non-adjustable					
	Heating element	AC 230 V, 5 W					
Norms and standards	Medium temperature	Permissible temperature of medium in the assembled valve: 120°C					
	CE conformity						
	EMC standard	2004/108/EC					
	Immunity	EN 61000-6-2:[2005]		EN 61000-6-2 Industrial			
	Emission	EN 61000-6-3: [2007]		EN 61000-6-4 Industrial			
	Low voltage directive	2006/95/EC		2006/95/EC			
	Electrical safety	EN 60730-1					
	Electromagnetic compatibility	Covered by EN 61000-6-2:[2005] Industrial EN 61000-6-3:[2007] Residential			EN 55011:[2007]		
	Product standards for automatic electrical controls	EN 60730-1:[2000] EN 60730-2-14:[1997]		DIN EN 61010-1:[2002]			
	C-tick	N474					
	Housing protection standard	IP 44 to IEC 60529		IP 67 to IEC 60529			
	Protection class	III or II to EN 60730					
	Environmental compatibility	Environmental compatibility	ISO 14001 (Environment)				
		ISO 9001 (Quality)					
		SN 36350 (Environmentally compatible products)					
		RL 2002/95/EG (RoHS)					
Dimensions / weight	Flanges and shaft connection to actuator	EN ISO 5211 F04 / F05 F07 F10				□ 32mm F12 / F16	
	Dimensions	see «Dimensions»					
	Cable glands	4 x Ø 20,5 mm (for M20)		2 x M20			
	Weight	1.4 kg	4.5 kg	7 kg	14 kg	25 kg	
Materials	Housing base, yoke	die-cast aluminum					
	Cover	plastic		die-cast aluminum			

¹⁾ These values apply at nominal voltage, at an ambient temperature of 20 °C and at the specified nominal running time

²⁾ Variable positioning time with SEZ31.1 auxiliary module (see below)

Accessories for SQL35.00 / 85.00			Weight
<ul style="list-style-type: none"> Double auxiliary switch ASC9.5 / ASC9.4 	Switching capacity	AC 250 V, 10 A resistive, 3 A inductive	ASC9.4 85 g
	Switching differential	approx. 1°	ASC9.5 30 g
<ul style="list-style-type: none"> Auxiliary switch with potentiometer ASZ7.4 	Switching capacity	AC 250 V, 10 A resistive, 3 A inductive	60 g
	Switching differential	approx. 1°	
	Change in resistance	0 ... 1000 Ω corresponding to 0 ... 90°	

Accessories for SQL36E..			Weight
<ul style="list-style-type: none"> Double auxiliary switch ASC36 	Switching capacity	AC 250 V, 3 A resistive, 1.5 A inductive	60 g
	Switching differential	approx. 1°	
<ul style="list-style-type: none"> Potentiometer ASZ36 	Change in resistance	0...1000 Ω corresponding to 0...90°	50 g
<ul style="list-style-type: none"> Auxiliary module SEZ31.1 	Positioning time for 90° at 50 Hz	SQL36E65: 30...180 s SQL36E110: 60...360 s SQL36E160: 120...720 s	60 g

General ambient conditions	Operation		Transport	Storage
	EN 60721-3-3 SQL35.00 / SQL85.00	EN 60721-3-4 SQL36E..	EN 60721-3-2 SQL35.00 / SQL85.00 / SQL36E..	EN 60721-3-1
Environmental conditions	Class 3K5	Class 4K2	Class 2K3	Class 1K3
Temperature	-15...+55 °C	-20...+70 °C	-30...+65 °C	-15...+55 °C
Humidity	5...95 % r. h.	15...100 % r. h.	< 95 % r. h.	0...95 % r. h.

Internal diagrams

SQL35.00

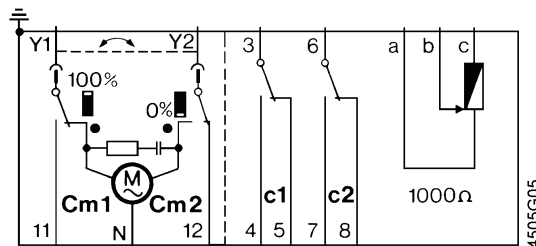

Cm1 End switch (non-adjustable)
Cm2 End switch (non-adjustable)
c1 1 auxiliary switch **ASC9.5**
or
c1, c2 1 double auxiliary switch **ASC9.4**
or
c1, 1000 Ω 1 built-in unit **ASZ7.4**
(1 auxiliary switch and
1 potentiometer)
N Neutral conductor
G System potential
Y1 Control phase OPEN
Y2 Control phase CLOSED
11 Sequence Y1 at 90°
12 Sequence Y2 at 0°

SQL85.00

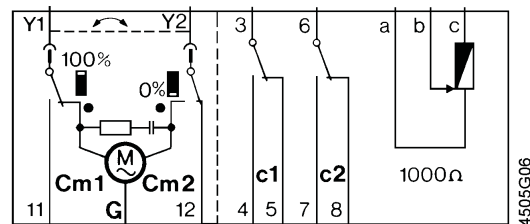

N Neutral conductor
G System potential
Y1 Control phase OPEN
Y2 Control phase CLOSED
11 Sequence Y1 at 90°
12 Sequence Y2 at 0°

SQL36E50F04
SQL36E50F05

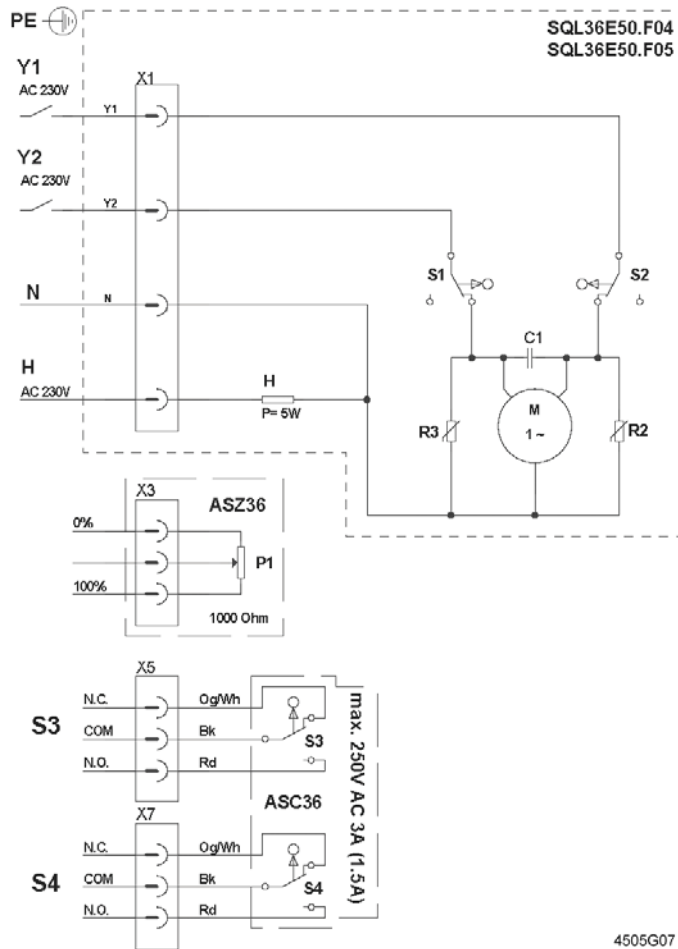

- S1 End switch CLOSED (non-adjustable)
- S2 End switch OPEN (non-adjustable)
- S3 Auxiliary switch CLOSED (ASC36)
- S4 Auxiliary switch OPEN (ASC36)
- H Heating element
- P1 Potentiometer (ASZ36)
- Y1 Control phase OPEN
- Y2 Control phase CLOSED
- N Neutral conductor
- N.C. Normally Closed
- N.O. Normally Open
- COM Common conductor

4505G07

SQL36E65
SQL36E110
SQL36E160

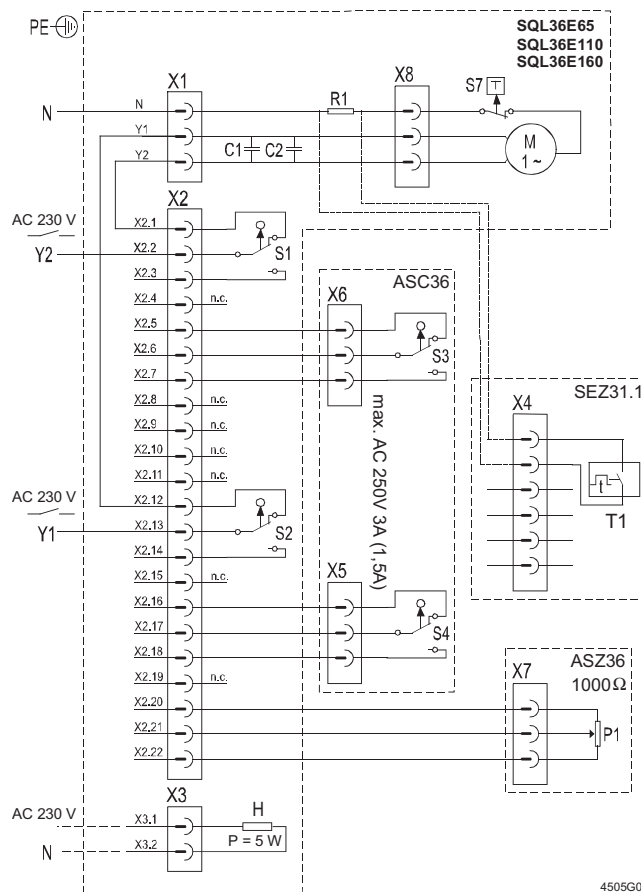

- S1 End switch CLOSED (non-adjustable)
- S2 End switch OPEN (non-adjustable)
- S3 Auxiliary switch CLOSED (ASC36)
- S4 Auxiliary switch OPEN (ASC36)
- S7 Thermal switch (integrated)
- H Heating element
- P1 Potentiometer (ASZ36)
- T1 Auxiliary module (SEZ31.1)
- Y1 Control phase OPEN
- Y2 Control phase CLOSED
- N Neutral conductor

4505G01

Connection diagrams

SQL35.00
SQL36E..

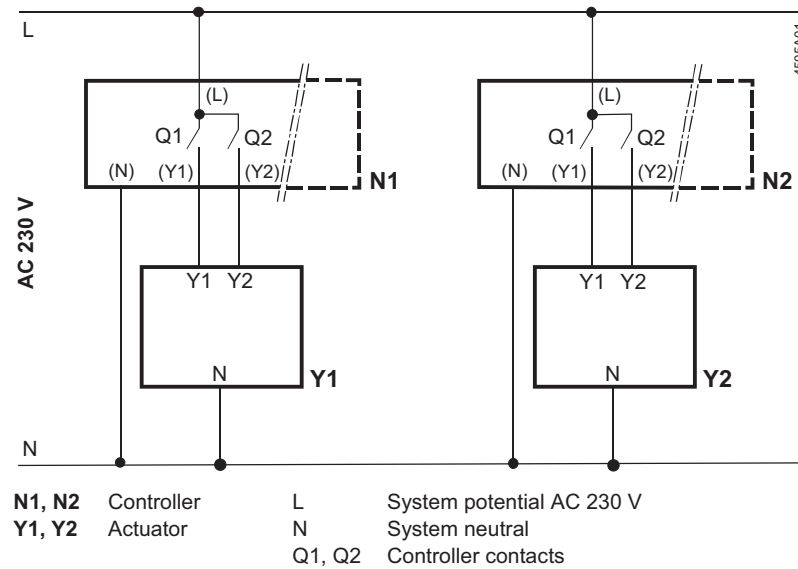

SQL85.00

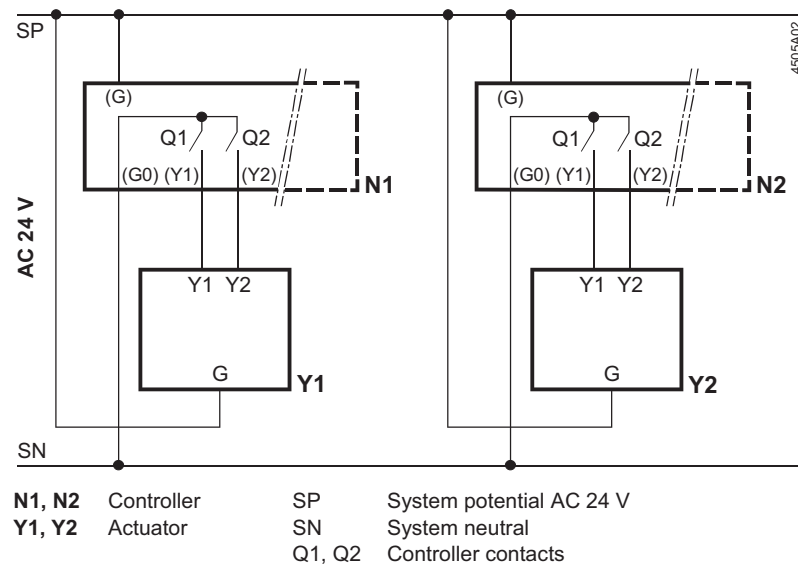

Dimensions

SQL35.00
SQL85.00

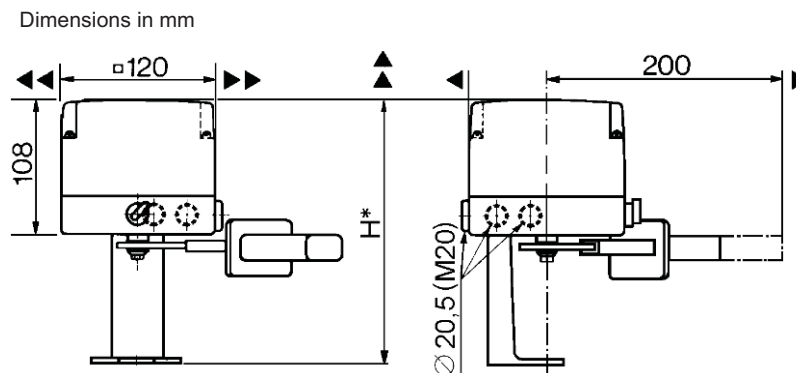



* Mounting height of actuator including ASK35... mounting set = 168 mm

▲ > 100 mm: Minimum clearance from wall or ceiling

▲ > 200 mm: For mounting, connection, operation, service, etc.

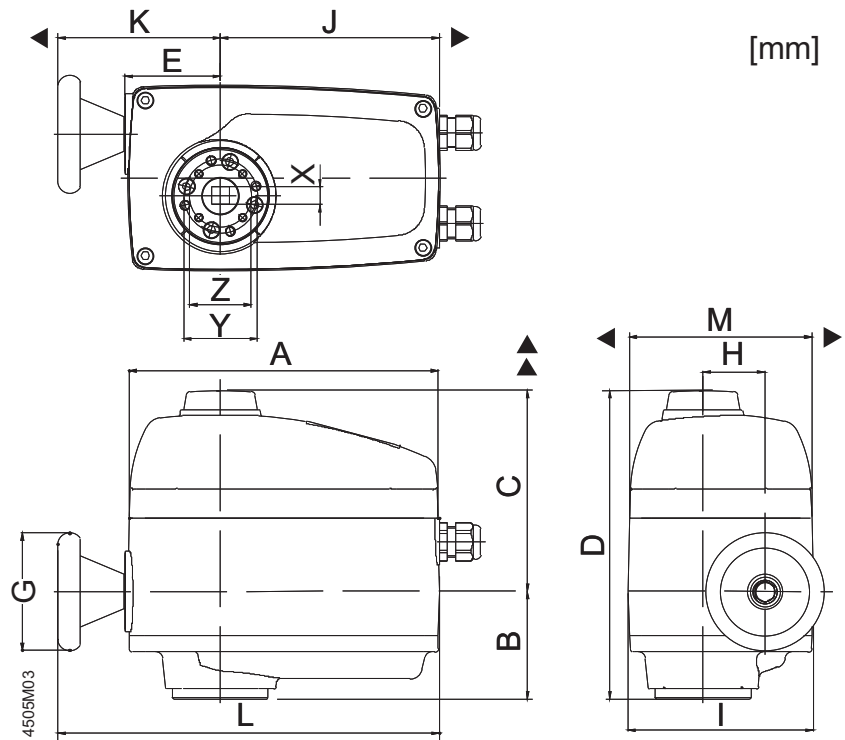
SQL36E50F04
SQL36E50F05



	SQL36E50F04	SQL36E50F05
DN	40...65	80...125
A	210	
B	73	
C	137	
D	210	
E	65	
G	Ø 80	
H	42	
I	126	
J	149	
K	110	
L	259	
M	124	
X	□ 11	□ 14
Y	42	
Z		50
EN 5211	F04	F05
 kg	4.5 kg	

◄ > 100 mm: Minimum clearance from wall or ceiling

▲ > 200 mm: For mounting, connection, operation, service, etc.

SQL36E65
 SQL36E110
 SQL36E160

[mm]

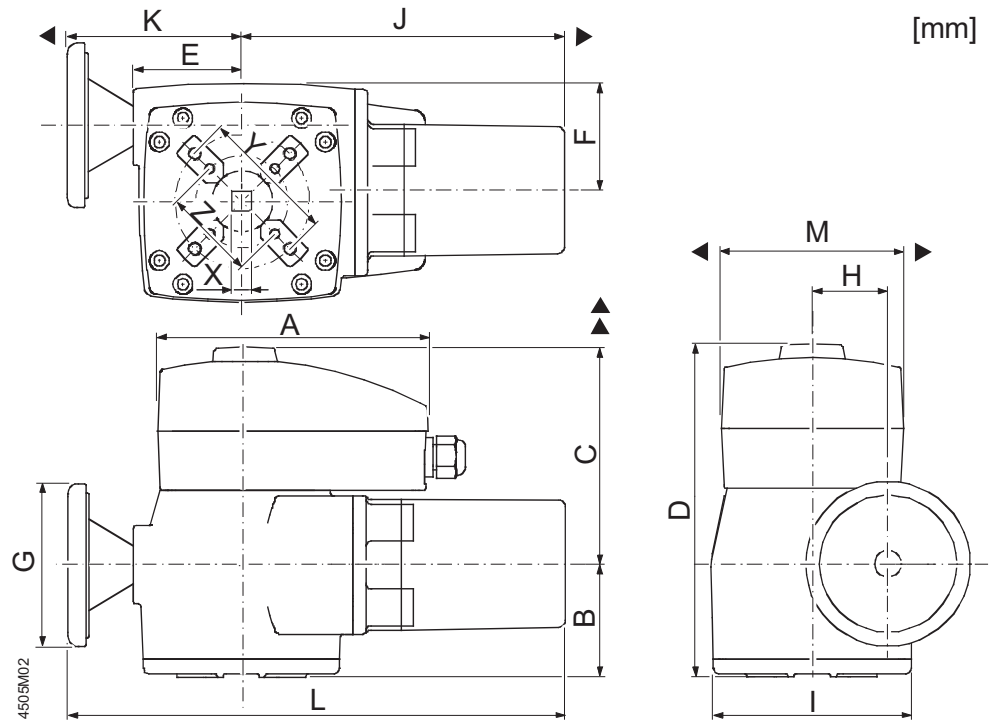

	SQL36E65	SQL36E110	SQL36E160
DN	150...200	250...400	(350) 450...600 ¹⁾
A	208	208	208
B	78	88	112
C	157	169	170
D	235	257	282
E	65	81	110
F	65	87	126
G	Ø 80	Ø 125	Ø 200
H	42	58	89
I	125	150	175
J	171	247	280
K	119	136	157
L	290	383	437
M	139	139	139
X	□ 17	□ 22	□ 32
Y	70	102	165
Z	50	70	125
EN 5211	F07	F10	²⁾
kg	7 kg	14 kg	25 kg

¹⁾ DN 350 / 400: VKF46.350TS, VKF46.400TS

²⁾ EN 5211 F12 / F16 flange connections for third-party butterfly valves are available on request.

◀ > 100 mm: Minimum clearance from wall or ceiling

▲ > 200 mm: For mounting, connection, operation, service, etc.

Spare parts

Order numbers for spare parts

	Cover	Knob	Tappet	Lever
				
Type		Changeover Auto/Man	Metal	Plastic
SQL35.00	410455408	426355058	467655618	426855068
SQL85.00	410455408	426355058	467655618	426855068

Revision numbers

Product number	Valid from rev. no.
SQL35.00	..D
SQL85.00	..D
SQL36E50F04	..A
SQL36E50F05	..A
SQL36E65	..A
SQL36E110	..A
SQL36E160	..A

