



RAB11



RAB11.1

Room thermostats

RAB11...

For 2-pipe fan coils

- Room thermostat with manual switch for heating or cooling mode and fan function
- 2-position control
- Manual 3-speed fan switch
- Switching voltage AC 250 V
- Control output ON/OFF

Use

The RAB11... room thermostat is used in heating or cooling systems to maintain the selected room temperature.

Typical use:

- Commercial buildings
- Residential buildings
- Light industrial buildings

In conjunction with

- zone valves
- thermal valves
- fans

Functions

Heating

If the room temperature falls below the selected setpoint, the thermostat's heating contact will close.

Cooling

If the room temperature exceeds the selected setpoint, the thermostat's cooling contact will close.

Fan speed

There are 2 possibilities to control the fan speed:

- Manually by means of the thermostat's 3-speed fan switch for continuous operation (RAB11 and RAB11.1).
- Automatically by switching to the selected fan speed via the thermostat for controlled operation. In that case – prior to commissioning – the jumper position corresponding to the thermostat function must be selected. There are 2 choices of jumper positions available on the printed circuit boards of the RAB11 and RAB11.1.

Jumper SR1 

Selected fan speed as continuous operation

Jumper SR2  Auto

Fan is switched at the same time as the valve

Ventilation

When the ventilation function  is selected (RAB11.1) with the slide switch on the unit front, the heating and cooling contacts are always open and the fan operates at the selected speed.

Changeover

Heating or cooling mode is selected with the switch located on the unit front (RAB11...).

Function diagrams

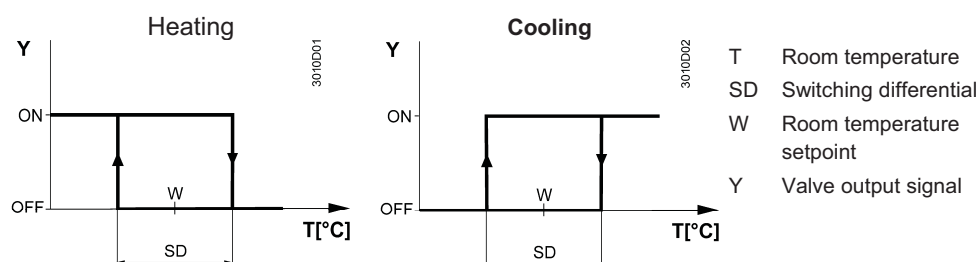

Type summary

2-pipe fan coil room thermostat for use with 3-speed fan, manual changeover

RAB11

2-pipe fan coil room thermostat for use with 3-speed fan, manual changeover and ventilation function

RAB11.1

Equipment combinations

Typ of unit	Product no. (ASN)	Data sheet
Motric on / off actuator	SFA21...	4863
Thermal actuator (for radiator valves)	STA21...	4893
Thermal actuator (for small valves 2.5 mm)	STP21...	4878

Accessories

Typ of unit	Product no. (ASN)
Adapter plate 120 x 120 mm for 4 x 4" conduit boxes	ARG70
Adapter plate 96 x 120 mm for 2 x 4" conduit boxes	ARG70.1
Adapter plate for surface wiring 112 x 130 mm	ARG70.2

Technical design

Key features of the RAB11... fan coil room thermostat:

- 2-position control
- Gas-filled diaphragm

Adjustments

The required temperature setpoint is selected with the setting knob on the front of the thermostat.

The setpoint setting range can be mechanically limited by means of a setpoint limiter under the unit cover.

Note

Mounting, installation and commissioning

The thermostat should be located where the room temperature can be acquired as accurately as possible, without getting adversely affected by direct solar radiation or other heat or refrigeration sources.

Mounting height is about 1.5 m above the floor.

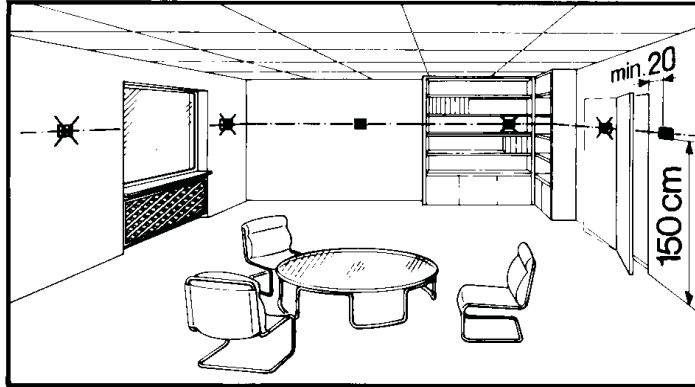

The thermostat can be fitted to most commercially available recessed conduit boxes or directly on the wall.



Caution: 250 V!

Only authorized personnel may open the unit to perform service
The unit must be isolated from the mains supply before opening.

When installing the unit, fix the baseplate first, then hook on the thermostat body and make the electrical connections. Then, fit the cover and secure it (also refer to separate mounting instructions).

The thermostat must be mounted on a flat wall.

The local electrical regulations must be complied with.

If there are thermostatic radiator valves in the reference room, set them to their fully open position.

Maintenance

Mechanical design

The room thermostat is maintenance-free.

The diaphragm is filled with environmentally friendly gas.

The housing is made of plastic.

Ordering

Typ (ASN)	Partnumber (SSN)	Description
RAB11	S55700-T225	Room thermostat RAB11
RAB11.1	S55700-T226	Room thermostat RAB11.1

Technical data

Power supply	Switching capacity control output: Y	
	Voltage / frequency	AC 250 V / 50 or 60 Hz
	Current	0.2...6(2) A
	Switching capacity fan: Q1, Q2, Q3	
	Voltage / frequency	AC 250 V / 50 or 60 Hz
	Current RAB11 / RAB11.1	0.2...6(2) A
	Screw terminals for	2 x 1.5 mm ² (min. 0.5 mm ²)
Operational data	Switching differential SD	≤1 K
	Setpoint setting range	8...30 °C
Environmental conditions	Operation	to IEC 721-3-3
	Climatic conditions	Class 3K5
	Temperature	0...+50 °C
	Humidity	<95 % r.h.
	Pollution degree	normal, to EN 60730-1
	Transport / Storage	to IEC 721-3-2
Industry standards	Climatic conditions	Class 2K3/1K3
	Temperature	-20...+50 °C
	Humidity	<95 % r.h.
	Mechanical conditions	Class 2M2
	Electromagnetic compatibility	
	Emissions (Residential, business and commercial)	EN 55014
CE- Conformity	EMC guidelines	2004/108/EC
	Low voltage directive	2006/95/EC
V- Conformity	Australian EMC Framework	CISPR 14-1: 2009
	Radio Interference Emission Standard	
Environmental compatibility		
The product environmental declaration		2002/95/EC (RoHS)
Safety standard		II to EN 60730-1
Degree of protection of housing		IP30 to EN 60529
Weight		0.14 kg
Colour		white, NCS S 0502-G (RAL 9003)

Disposal



Dispose of the device as electronic waste in compliance with European directive 2002/96/EEC (WEEE) and not as municipal waste. Observe all relevant national regulations and dispose of the unit correctly. Observe all local and applicable laws.

Connection diagram

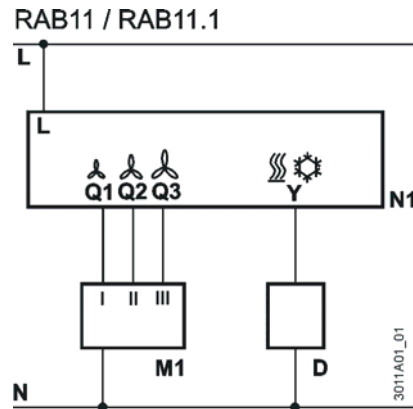

- L Switching voltage AC 250 V
- N Neutral conductor
- M1 3-speed fan
- D Thermal valve or zone valve
- N1 Room thermostat RAB11/ RAB11.1
- Q1 Control output
"Fan speed I", AC 250 V
- Q2 Control output
"Fan speed II", AC 250 V
- Q3 Control output
"Fan speed III", AC 250 V
- Y Control output
"Valve actuator heating/cooling",
AC 250 V

Dimensions

Room thermostat

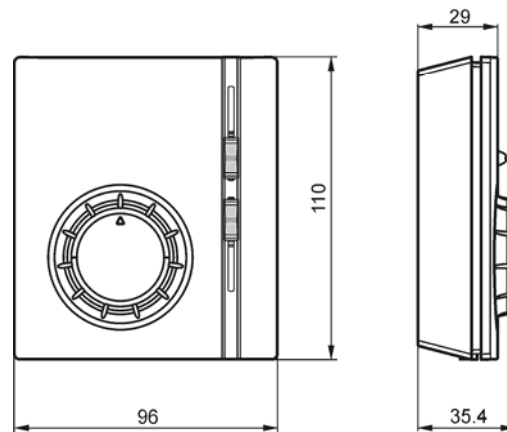

Baseplate

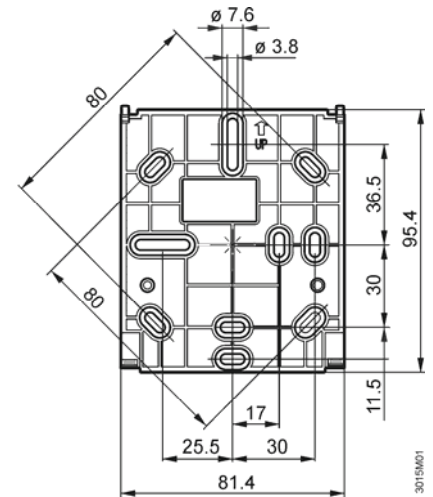

Remark

Heating:

Because of the unavoidable self heating effects of the electrical current, any loads of more than 3 Amperes connected to the unit can influence the control behavior and temperature accuracy in a negative way.

Cooling:

Because of the unavoidable self heating effects of the electrical current, any loads of more than 1 Amperes connected to the unit can influence the control behavior and temperature accuracy in a negative way.

