

RVAN...

Valve actuator, 230 V or 24 V supply voltage and 3–point or 0(2)...10 V DC control



Valve actuator for control of Regin's range of valves. Available in models with actuator force of 500, 1000, 1800 or 2500 N. The actuators can be operated manually with the manual override mechanism on the lid. Using an adapter kit, the actuator can also be adapted for use with other valves on the market.

- ✓ Stroke 10...30 mm (500 N, 1000 N), 10...52 mm (1800 N, 2500 N)
- ✓ Manual operation
- ✓ Automatic stroke adjustment (only RVAN...24A range)
- ✓ Position indication
- ✓ Force 500...2500 N

Function

Stroke and end position calibration

Stroke and end position calibration is not necessary due to a construction utilizing end position stops. When the valve reaches the end position, a force is generated. Once the force of the actuator reaches a predefined level, the limit switch automatically halts the drive motor.

Position indications

There are two position indications for the stem, one red and one blue. They can be used for end position indication, since they accompany the stem to its end position. They can also be switched to indicate whether the valve is opening or closing.

Manual override

The valve position can be changed manually using the knob located in the actuator lid.

Indications

Only for RVAN...24A range. The actuator has two LED with indications according to the table below.

Indication	Description
Green steady light	Actuator working properly.
Green light quick flashing	Test run in progress.
Green light slow flashing	The setting was changed during the operation. The new setting will be valid after the next power on.
Red and green steady light	End position reached.
Red light slow flashing	Override input mode Operation faulty; either the improper installation or the valve stroke lost.
Red light quick flashing	Manual override mode.

HEAD OFFICE SWEDEN

Phone: +46 31 720 02 00

Web: www.regincontrols.com

E-mail: info@regincontrols.com

RVAN...

— | —

Installation

The valve and actuator should never be mounted at an angle of more than 90°.

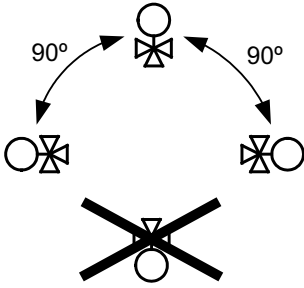

Technical data

Ambient temperature	0...50 °C
Storage temperature	-40...80 °C
Ambient humidity	10...90 % RH
Protection class	IP54

Models

Article	Supply voltage	Control signal	Max. power consumption	Force	Stroke	Stroke time
RVAN5-230	230 V AC ±15 %, 50 Hz	3-point	15.3 W / 16.5 VA	500 N	10...30 mm	3 s/mm
RVAN10-230	230 V AC ±15 %, 50 Hz	3-point	15.3 W / 16.5 VA	1000 N	10...30 mm	3 s/mm
RVAN18-230	230 V AC ±15 %, 50 Hz	3-point	15.3 W / 16.5 VA	1800 N	10...52 mm	3 s/mm
RVAN25-230	230 V AC ±15 %, 50 Hz	3-point	15.3 W / 16.5 VA	2500 N	10...52 mm	3 s/mm
RVAN5-24	24 V AC ±15 %	3-point	7.8 W / 8.0 VA	500 N	10...30 mm	3 s/mm
RVAN10-24	24 V AC ±15 %	3-point	6.2 W / 6.7 VA	1000 N	10...30 mm	3 s/mm
RVAN18-24	24 V AC ±15 %	3-point	10.9 W / 11.7 VA	1800 N	10...52 mm	3 s/mm
RVAN25-24	24 V AC ±15 %	3-point	10.9 W / 11.7 VA	2500 N	10...52 mm	3 s/mm
RVAN5-24A	24 V AC/DC ±15 %	0...10 V DC, 2...10 V DC or 4...20 mA. ¹	5.1 W / 13.9 VA	500 N	10...30 mm	1.5 s/mm
RVAN10-24A	24 V AC/DC ±15 %	0...10 V DC, 2...10 V DC or 4...20 mA. ¹	6.2 W / 17.4 VA	1000 N	10...30 mm	1.5 s/mm
RVAN18-24A	24 V AC/DC ±15 %	0...10 V DC, 2...10 V DC or 4...20 mA. ¹	8.6 W / 22.4 VA	1800 N	10...52 mm	3 s/mm
RVAN25-24A	24 V AC/DC ±15 %	0...10 V DC, 2...10 V DC or 4...20 mA. ¹	8.6 W / 22.4 VA	2500 N	10...52 mm	3 s/mm



This product carries the CE-mark. More information is available at www.regincontrols.com.

DIP switches - only RVAN...24A

SW	1 (On)	0 (Off)
SW1	Spindle down when the valve is closed	Spindle up when the valve is closed (FS = factory setting)
SW2	LOG	LIN (FS)
SW3	Y = 2...10 V DC	Y = 0...10 V DC (FS)
SW4	Reverse operation	Direct operation (FS)
SW5	Y signal split in accordance with the setting of SW6	No split function (FS)
SW6	5(6)...10 V = 0...100%	0(2)...5(6) V = 0...100% (FS)

1. For 4...20 mA control signal, a 500 Ω resistor must be mounted parallel to the input signal, i.e. between terminals 2 and 3. SW3 should be in position 1 (On).

Dimensions

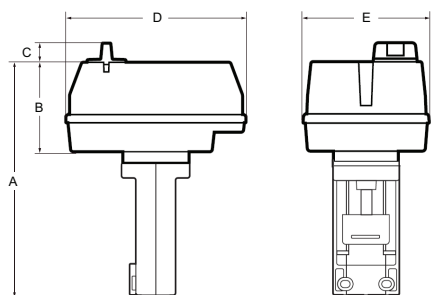

Model	A	B	C	D	E
RVAN5-230	248	95	16	198	133
RVAN10-230	248	95	16	198	133
RVAN18-230	293	95	16	198	133
RVAN25-230	293	95	16	198	133

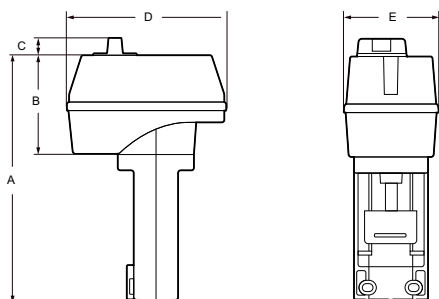

Model	A	B	C	D	E
RVAN5-24, RVAN5-24A	237	95	16	150	85
RVAN10-24, RVAN10-24A	248	95	16	198	133
RVAN18-24, RVAN18-24A	293	95	16	198	133
RVAN25-24, RVAN25-24A	293	95	16	198	133

[mm], unless otherwise specified

Wiring

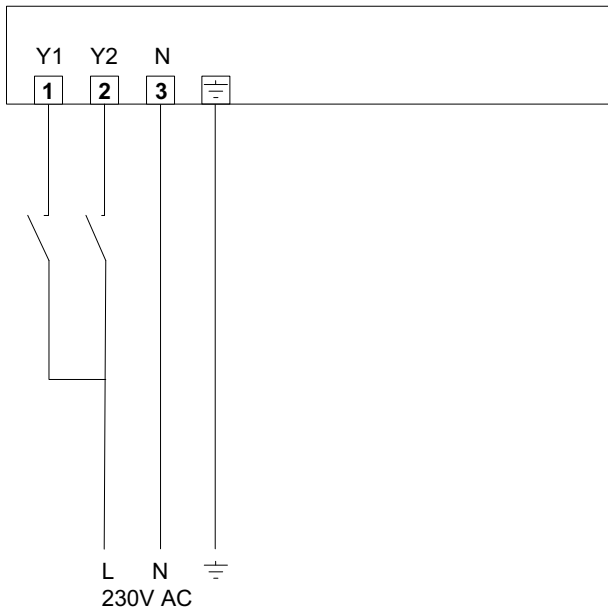

Fig. 1 RVAN...230: Y1 circuit closed = Actuator spindle is extending from the actuator; Y2 circuit closed = Actuator spindle is retracting into the actuator

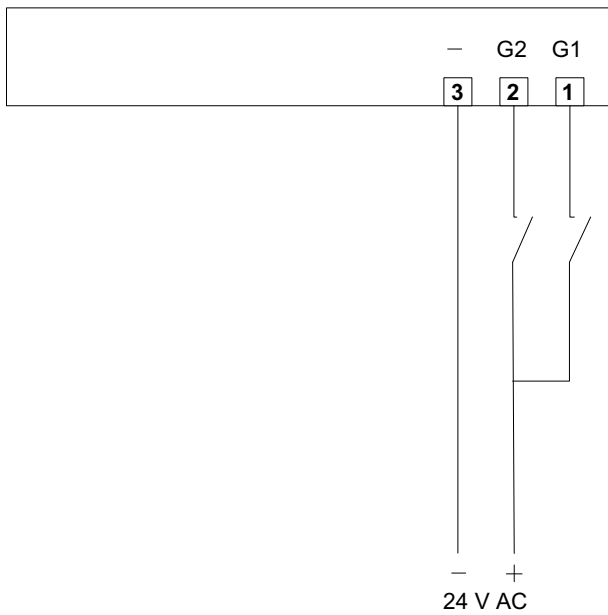

Fig. 2 RVAN...24: G1 closed = Actuator spindle extending; G2 closed = Actuator spindle retracting

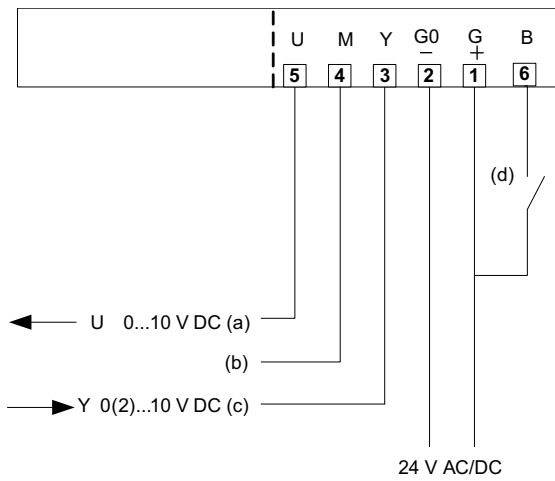

Fig. 3 RVAN...24A: (a) Measuring voltage for position indication; (b) Signal neutral; (c) Control signal from controller; (d) Override input or on/off control

Documentation

All documentation can be downloaded from www.regincontrols.com.