

Symaro™

Fine Dust Duct Sensors

QSM2100 / QSM2162 / AQS2100



The sensors acquire PM2.5 and PM10 concentrations, relative humidity and temperature

- Operating voltage AC 24 V or DC 15...35 V
- Signal outputs DC 0...10 V or DC 0...5 V or 4...20 mA adjustable
- Range of use -5...45 °C / 5...95 % r.h. (non-condensing)

Use

In air ducts of ventilation and air conditioning plants to enhance room comfort and optimize energy consumption by providing demand-controlled ventilation. The sensor acquires:

- PM2.5 & PM10 concentrations
- Relative humidity of duct air
- Duct air temperature

NOTICE!

- Do not use the sensors as safety devices, such as gas or smoke warning devices!
- Do not use the sensors outdoors!

Type summary

Type	Order number	Description
QSM2100	S55720-S491	Fine dust duct sensor for PM2.5 and PM10
QSM2162	S55720-S492	Fine dust duct sensor for PM2.5 and PM10, temperature, relative humidity

Order and delivery

When ordering, provide both name and type reference, e.g. fine dust duct sensor QSM2100. The sensor is supplied complete with mounting flange, cable entry gland M16 and a pre-installed AQS2100 in fine dust duct sensor.

Accessory

Name	Type	Order number
Filter cap (for QSM2162 replacement)	AQF3101	–
Fine dust duct sensor module for replacement	AQS2100	S55720-S493

The accessory must be ordered separately.

Product documentation

Title	Document ID:
Mounting instructions (QSM21...)	A6V11892999
Mounting instructions (AQS2100)	A6V11910876
Basic documentation	A6V11893104
CE declaration	A5W00096641
RCM declaration	A5W00096643
Product environmental declaration	A5W00099435

All documentation can be downloaded at <http://siemens.com/bt/download>.

Equipment combinations

All systems and devices capable of processing the following sensor signals:

- DC 0...10 V or DC 0...5 V or 4...20 mA

Fine dust (PM2.5 & PM10)

The duct sensor acquires PM2.5 & PM10 concentrations. The output value is the moving average of latest sensor data within 10 s.

Relative humidity (QSM2162)

The duct sensor acquires the relative humidity in the air duct via its capacitive humidity sensing element whose electrical capacitance changes as a function of relative humidity. The electronic measuring circuit converts the sensor's signal to a continuous DC 0...10 V or DC 0...5 V or 4...20 mA signal, corresponding to a relative humidity range of 0...100 %.

Temperature (QSM2162)

The duct sensor acquires the temperature in the air duct via its sensing element whose electrical character changes as a function of the temperature.

The change is converted to an active DC 0...10 V or DC 0...5 V or 4...20 mA output signal ($\pm 0...50\text{ }^{\circ}\text{C}$ or $-35...+35\text{ }^{\circ}\text{C}$).

Mechanical design

The fine dust duct sensor consists of a housing, a printed circuit board, connection terminals, a mounting flange, and an immersion rod. The immersion rod of the QSM2162 has a measuring tip.

The bisectonal housing consists of a base and a removable cover (snap-on design). The measuring circuit and the setting elements are located on the printed circuit board inside the cover, the connection terminals are located on the base.

The humidity and temperature sensing elements are located at the end of the measuring probe and are protected by a filter cap.

Cable entry is made via the cable entry gland M16 (IP54) supplied with the sensor, to be screwed into the housing.

Immersion rod and housing are made of plastic and are rigidly connected.

The sensor is fitted with the mounting flange supplied with the sensor. The flange must be placed over the immersion rod and then secured as per the required immersion depth.

Setting element

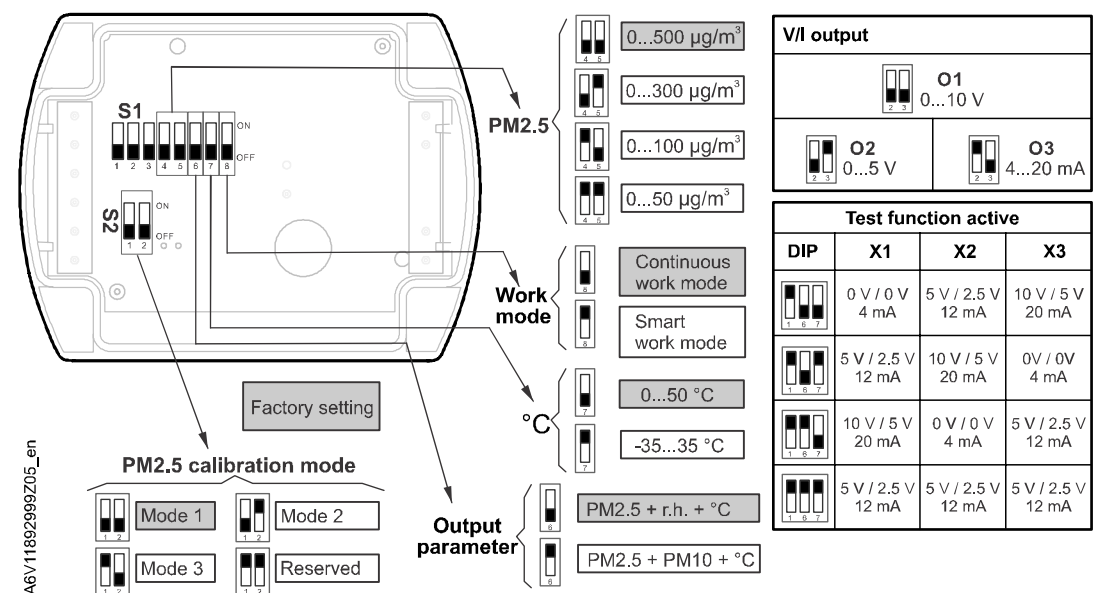

The setting elements are located inside the cover.

DIP switch configuration

The sensor has two sets of DIP switches: S1 and S2.

The different DIP switch positions mean the following:

S1

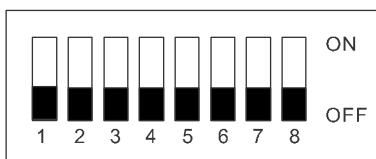

Test mode	V/I output		PM2.5 range selection		Output parameter selection	Temperature range selection	Work mode	Function
	2	3	4	5				
–	OFF	OFF	–	–	–	–	–	DC 0...10 V (default)
–	OFF	ON	–	–	–	–	–	DC 0...5 V
–	ON	OFF	–	–	–	–	–	4...20 mA
–	ON	ON	–	–	–	–	–	Back to default
–	–	–	OFF	OFF	–	–	–	0...500 µg/m³ (default)
–	–	–	OFF	ON	–	–	–	0...300 µg/m ³
–	–	–	ON	OFF	–	–	–	0...100 µg/m ³
–	–	–	ON	ON	–	–	–	0...50 µg/m ³
–	–	–	–	–	OFF	–	–	PM2.5 + r.h. + temperature (default) ²⁾
–	–	–	–	–	ON	–	–	PM2.5 + PM10 + temperature ²⁾
–	–	–	–	–	–	OFF	–	0...50 °C (default) ²⁾
–	–	–	–	–	–	ON	–	-35...35 °C ²⁾
–	–	–	–	–	–	–	OFF	Continuous work mode (default)
–	–	–	–	–	–	–	ON	Smart work mode
ON	–	–	–	–	OFF	OFF	–	Test MODE 1 ¹⁾
ON	–	–	–	–	OFF	ON	–	Test MODE 2 ¹⁾
ON	–	–	–	–	ON	OFF	–	Test MODE 3 ¹⁾
ON	–	–	–	–	ON	ON	–	Test MODE 4 ¹⁾

Note:

¹⁾ For detailed information on the test mode, see Activating test function [→ 4].

²⁾ These functions are only for QSM2162.

Activating test function

Use the test function to check whether the sensor value inaccuracy is caused by the analog output error. Users can configure DIP1, DIP6 and DIP7 to check if the actual signal output of terminals (X1, X2, X3) corresponds to the values defined in Test function active [→ 5] table. Test function of X3 is valid only for QSM2162.

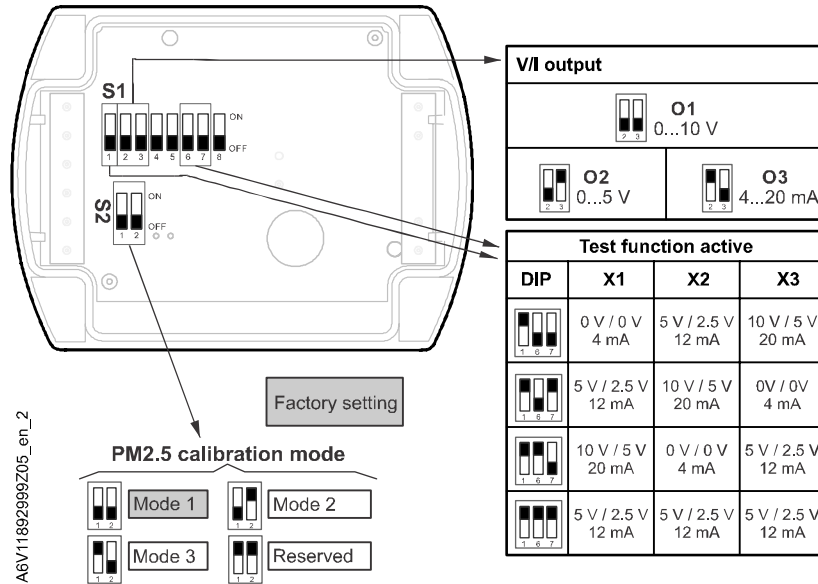

Test function active					
DIP			X1	X2	X3
DIP1 (ON)	DIP6 (OFF)	DIP7 (OFF)	0 V / 0 V 4 mA	5 V / 2.5 V 12 mA	10 V / 5 V 20 mA
DIP1 (ON)	DIP6 (OFF)	DIP7 (ON)	5 V / 2.5 V 12 mA	10 V / 5 V 20 mA	0 V / 0 V 4 mA
DIP1 (ON)	DIP6 (ON)	DIP7 (OFF)	10 V / 5 V 20 mA	0 V / 0 V 4 mA	5 V / 2.5 V 12 mA
DIP1 (ON)	DIP6 (ON)	DIP7 (ON)	5 V / 2.5 V 12 mA	5 V / 2.5 V 12 mA	5 V / 2.5 V 12 mA

S2



PM2.5 calibration mode ¹⁾		Function
1	2	
OFF	OFF	Mode 1 (default)
OFF	ON	Mode 2
ON	OFF	Mode 3
ON	ON	Reserved

Note:

¹⁾ Mode 1 is for standard use. Mode 2 and Mode 3 are for advanced application.

- Mode 1: The sensor is calibrated using the TSI device as reference in Arizona A1 dust.
- Mode 2: The sensor is calibrated using the GRIMM device as reference in Arizona A1 dust.
- Mode 3: The sensor is calibrated using the GRIMM device as reference in KCL dust.

Malfunction

QSM2100 (PM2.5 + PM10)

QSM2162 (PM2.5 + PM10 + temperature)

In the following table:

- High means the signal output of terminal is 10 V/5 V/20 mA after 60 s.
- Low means the signal output of terminal is 0 V/0 V/4 mA after 60 s.

Malfunction	Signal output			Product	
	X1 (PM2.5)	X2 (PM10)	X3 (Temperature)	QSM2100	QSM2162
PM2.5 communication error	High	High	High	–	√
	High	High	–	√ ^{*)}	–
PM2.5 sensor module replacement warning	High	Low	Normal output	–	√
	High	Low	–	√	–
Temperature sensor fault	Normal output	Normal output	High	–	√

Notes:

^{*)} If the signal output of X1 & X2 is 10 V or 20 mA, the cause of the error is one of the following:

- The selected measuring range of PM2.5 & PM10 is below the measured PM2.5 or PM10 value. E.g., if the selected measure range is 0...50 µg/m³, but the measured PM2.5 or PM10 value is 100 µg/m³, the signal output of X1 & X2 will be 10 V or 20 mA. Selecting a higher range resolves this error.
- If the signal output is still 10 V or 20 mA after changing the selected measuring range, the cause is a PM2.5 communication error.

QSM2162 (PM2.5 + r.h. + temperature)

In the following table:

- High means the signal output of terminal is 10 V/5 V/20 mA after 60 s.
- Low means the signal output of terminal is 0 V/0 V/4 mA after 60 s.

Malfunction	Signal output		
	X1 (PM2.5)	X2 (r.h.)	X3 (Temperature)
PM2.5 communication error	High	High	High
PM2.5 sensor module replacement warning	High	High	Low
Temperature sensor fault	Normal output	High	Low
Humidity sensor fault	Normal output	High	Normal output

Sensor data refresh frequency

The sensor data refresh frequency only applies to smart work mode (DIP8 = ON). It is defined as per the real-time concentration of PM2.5 & PM10 and the interval is 3...8 min. The data is updated under the following conditions:

	Interval						
	8 min	7 min	6 min	5 min	4 min	3 min	Continuous
Concentration	Differential between real-time and last measurement						
< 100 µg/m ³	±2 µg/m ³	±4 µg/m ³	±6 µg/m ³	±8 µg/m ³	±10 µg/m ³	±12 µg/m ³	Bigger
> 100 µg/m ³	±2 %	±4 %	±6 %	±8 %	±10 %	±12 %	Bigger

Security

	<p>⚠ CAUTION</p>
	<p>National safety regulations</p> <p>Failure to comply with national safety regulations may result in personal injury and property damage.</p> <ul style="list-style-type: none"> Observe national provisions and comply with the appropriate safety regulations.

Engineering

Powering the sensor requires a transformer for safety extra low-voltage (SELV) with separate windings for 100 % duty. When sizing and protecting the transformer, the local safety regulations must be complied with.

When sizing the transformer, the power consumption of the sensor must be taken into consideration.

For correct wiring, see the datasheets of the devices with which the sensor is used.

Observe permissible line lengths.

Cable routing and cable selection

Note that when routing cables, the longer the cables run side by side and the smaller the distance between them, the greater the electrical interference. Shielded cables must be used in environments with EMC problems.

Twisted pair cables are required for the secondary supply lines and the signal lines.

Mounting

Mounting location and orientation

To ensure degree of protection IP54, the sensor must be fitted with the cable entry pointing downward!

Mount the sensor where it can be easily accessed by service.

- If used after humidifier, a certain distance is required between humidifier and sensor, so that the vapor or mist generated by the humidifier can evaporate before reaching the sensor. This distance is marked on the diagram as B_M . The minimum distance between the humidifier and the sensor must be no less than B_M .

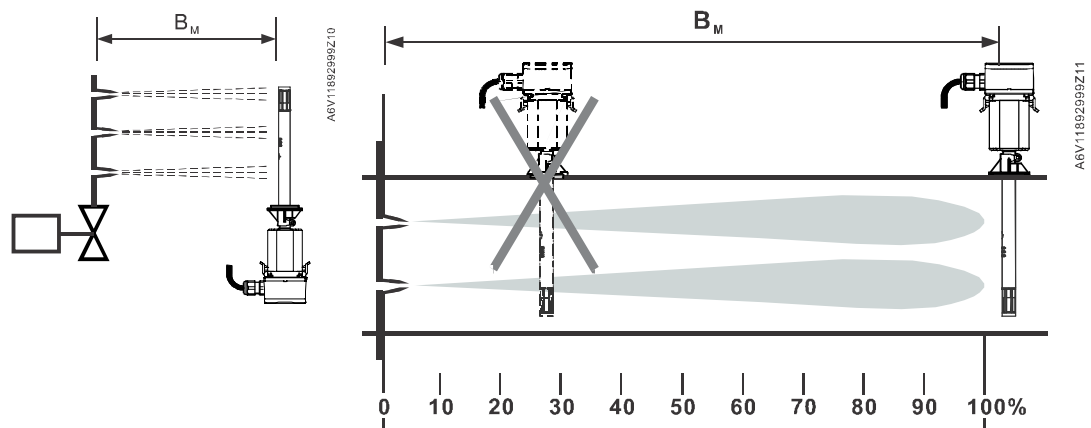

- Avoid any impact or shock to the sensing elements in the immersion rod.

- To avoid sunlight damage, do not mount the sensor on a rooftop. To ensure correct operation, the sensor's ambient temperature must be in the range of $-5\dots45\text{ }^{\circ}\text{C}$.
- The air inlet must be placed facing the air flow in order to achieve the uniformity and accuracy expected.

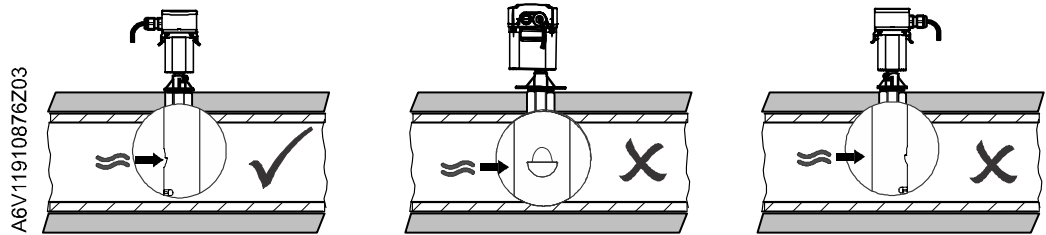

- Do not install the sensor in a vertical duct.

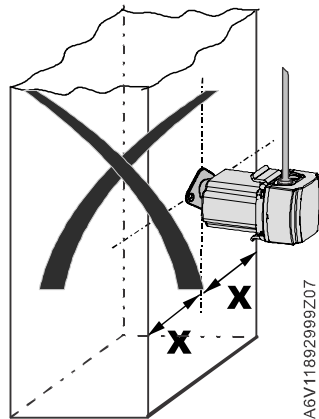

Mounting instructions

Mounting instructions are enclosed in the package.

Replacing AQS2100

NOTICE! Only trained engineers may replace the sensor module.

The sensor module must be replaced under the following conditions:

- QSM2162 (PM2.5 + r.h. + temperature): An output signal of 10 V/5 V/20 mA is provided at signal outputs X1 and X2 and an output signal of 0 V/4 mA at signal output X3.
- QSM2100/QSM2162 (PM2.5 + PM10 + temperature): An output signal of 10 V/5 V/20 mA is provided at signal output X1 and an output signal of 0 V/4 mA at signal output X2.

Replacing the sensor module:

NOTICE! As the replacement on QSM2162 and QSM2100 is identical, the steps to replace the QSM2162 sensor module serve as an example.

1. Detach the sub-housing from the main housing.

CAUTION! Avoid touching any exposed electrical elements.

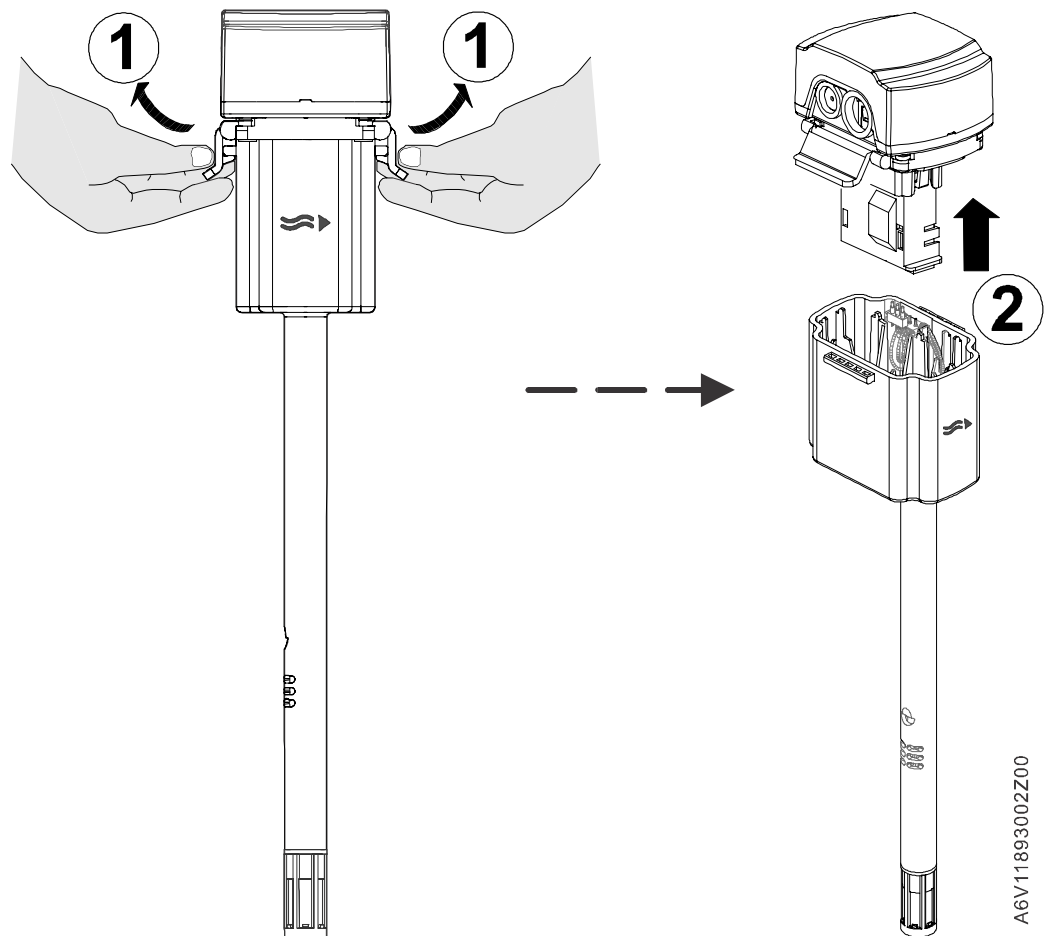

2. Remove the module by hand.

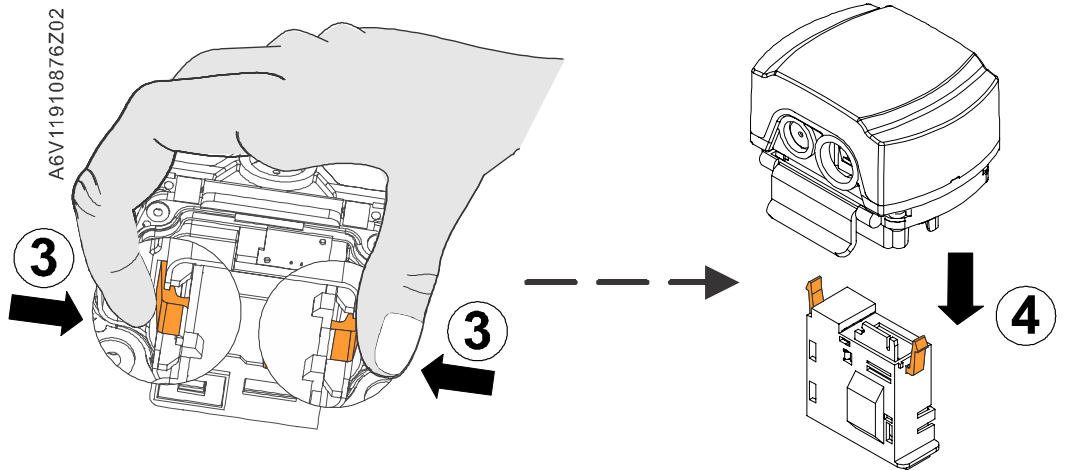

3. Replace the module by the new one.

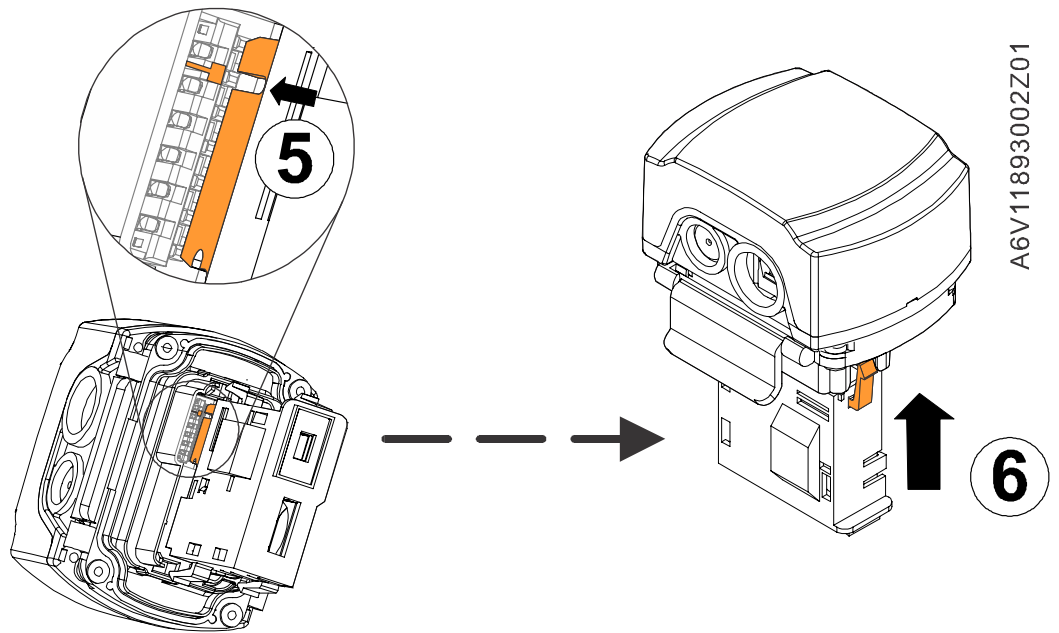

4. Install the sub-housing on the main housing.

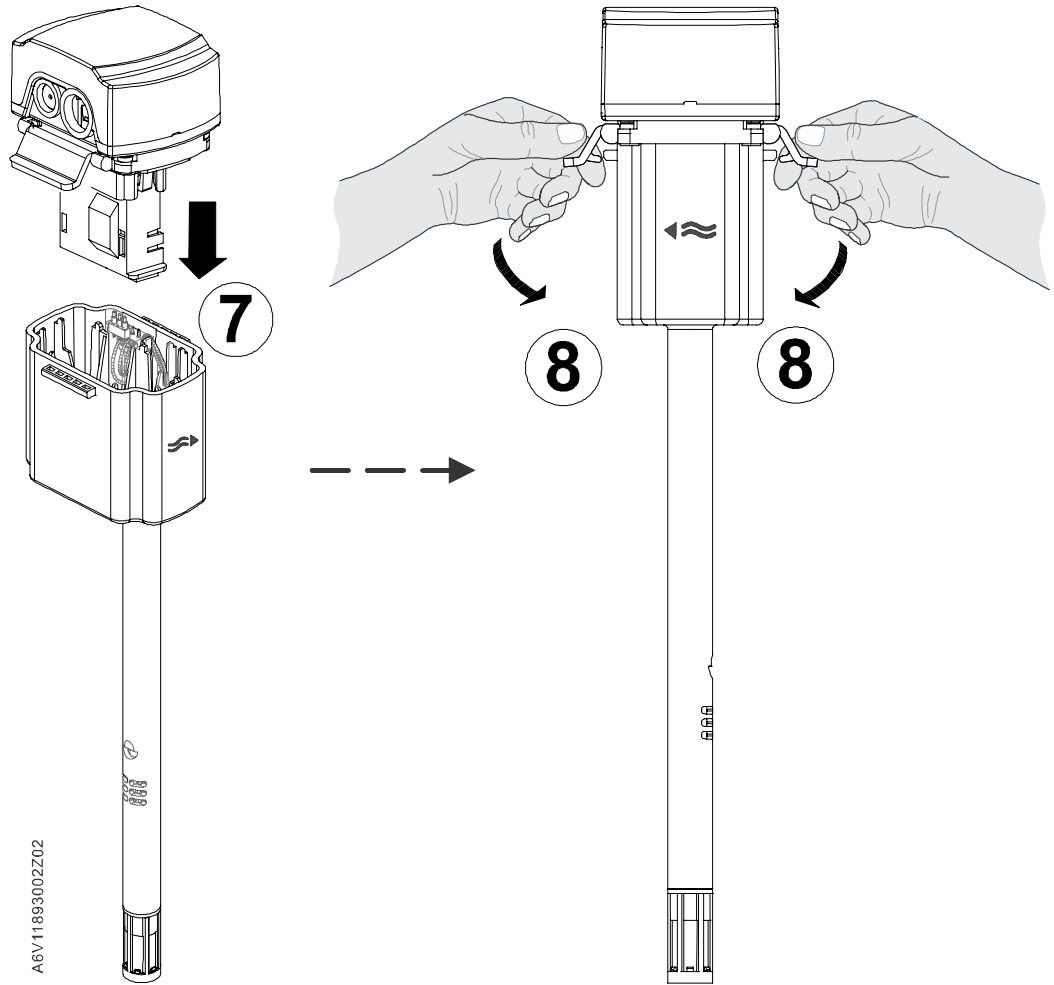

!	NOTICE
	Turn off the device before replacing the sensor module. If not possible, insert a new sensor module 10 s after the old one is removed.

Disposal

	<p>The device is considered an electronic device for disposal in accordance with the European Guidelines and may not be disposed of as domestic garbage.</p> <ul style="list-style-type: none">• Dispose of the device through channels provided for this purpose.• Comply with all local and currently applicable laws and regulations.
---	---

FCC (Federal Communications Commission)

This device complies with part 15 of the FCC rules. Operation is subject to the following two conditions:

1. This device may not cause harmful interference;
2. This device must accept any interference received, including interference that may cause undesired operation.

Changes or modifications not expressly approved by the party responsible for compliance could void the user's authority to operate the equipment.

NOTE: This equipment has been tested and found to comply with the limits for a Class B digital device, pursuant to part 15 of the FCC Rules. These limits are designed to provide reasonable protection against harmful interference in a residential installation. This equipment generates, uses and can radiate radio frequency energy and, if not installed and used in accordance with the instructions, may cause harmful interference to radio communications. However, there is no guarantee that interference will not occur in a particular installation. If this equipment does cause harmful interference to radio or television reception, which can be determined by turning the equipment off and on, the user is encouraged to try to correct the interference by one or more of the following measures:

- Reorient or relocate the receiving antenna.
- Increase the separation between the equipment and receiver.
- Connect the equipment into an outlet on a circuit different from that to which the receiver is connected.
- Consult the dealer or an experienced radio/TV technician for help.

FDA (Food and Drug Administration)

This device complies with IEC/EN 60825-1:2014, 21 CFR 1040.10 and 1040.11 except for conformance with IEC 60825-1 Ed. 3, as described in Laser Notice No. 56, dated May 8, 2019. It is subject to the following conditions:

- Class 1 laser product
- LASER RADIATION for laser module
- 655 nm, CW (continuous wave), for laser leakage < class 1 laser product limit (0.39 mW)

NOTE: The sensor module of fine dust duct sensor is fully enclosed, so no potentially hazardous radiation is accessible during use. In order to avoid inadvertent exposure to hazardous laser radiation, do not disassemble the housing of sensor module during operation or maintenance. If the housing is broken, do not use and replace with a new module.

Open Source Software (OSS)

All open source software components used within the product (including their copyright holders and the license conditions) can be found from the website <http://www.siemens.com/download?A6V11998673>.

Power supply	
Operating voltage	AC 24 V ± 20 % or DC 15...35 V (SELV) or AC/DC 24 V class 2 (US)
Frequency	50/60 Hz at AC 24 V
External supply line protection (EU)	Fuse slow max. 10 A or Circuit breaker max. 13 A Characteristic B, C, D according to EN 60898 or Power source with current limitation of max. 10 A
Power consumption QSM2100 QSM2162	3.2 VA 3.8 VA

Functional data (PM2.5)	
Measuring range (selectable)	<ul style="list-style-type: none"> 0...500 $\mu\text{g}/\text{m}^3$ (default) 0...300 $\mu\text{g}/\text{m}^3$ 0...100 $\mu\text{g}/\text{m}^3$ 0...50 $\mu\text{g}/\text{m}^3$
Unit to unit variability	0...100 $\mu\text{g}/\text{m}^3$: ± 13 $\mu\text{g}/\text{m}^3$, 100...500 $\mu\text{g}/\text{m}^3$: ± 15 % of reading @ <ul style="list-style-type: none"> 15...35 °C and 20...70 % r.h. Duct air speed: 2...10 m/s Direction of air inlet & outlet (after mounting): facing air flow
Analog output signal, (terminal X1)	<ul style="list-style-type: none"> DC 0...10 V or DC 0...5 V $\hat{=}$ (0...500 $\mu\text{g}/\text{m}^3$)/(0...300 $\mu\text{g}/\text{m}^3$)/(0...100 $\mu\text{g}/\text{m}^3$)/(0...50 $\mu\text{g}/\text{m}^3$), max. ± 1 mA 4...20 mA $\hat{=}$ (0...500 $\mu\text{g}/\text{m}^3$)/(0...300 $\mu\text{g}/\text{m}^3$)/(0...100 $\mu\text{g}/\text{m}^3$)/(0...50 $\mu\text{g}/\text{m}^3$), max. 500 ohm
Data update interval **)	<ul style="list-style-type: none"> Continuous work mode (default) 3...8 min (smart work mode)

Functional data (PM10)	
Measuring range (selectable)	<ul style="list-style-type: none"> 0...500 $\mu\text{g}/\text{m}^3$ (default) 0...300 $\mu\text{g}/\text{m}^3$ 0...100 $\mu\text{g}/\text{m}^3$ 0...50 $\mu\text{g}/\text{m}^3$
Unit to unit variability	0...100 $\mu\text{g}/\text{m}^3$: ± 15 $\mu\text{g}/\text{m}^3$, 100...500 $\mu\text{g}/\text{m}^3$: ± 20 % of reading @ <ul style="list-style-type: none"> 15...35 °C and 20...70 % r.h. Duct air speed: 2...10 m/s Direction of air inlet & outlet: facing air flow
Analog output signal, (terminal X2)	<ul style="list-style-type: none"> DC 0...10 V or DC 0...5 V $\hat{=}$ (0...500 $\mu\text{g}/\text{m}^3$)/(0...300 $\mu\text{g}/\text{m}^3$)/(0...100 $\mu\text{g}/\text{m}^3$)/(0...50 $\mu\text{g}/\text{m}^3$), max. ± 1 mA 4...20 mA $\hat{=}$ (0...500 $\mu\text{g}/\text{m}^3$)/(0...300 $\mu\text{g}/\text{m}^3$)/(0...100 $\mu\text{g}/\text{m}^3$)/(0...50 $\mu\text{g}/\text{m}^3$), max. 500 ohm
Data update interval **)	<ul style="list-style-type: none"> Continuous work mode (default) 3...8 min (smart work mode)

Functional data (temperature with QSM2162)	
Range of use	-5...45 °C
Measuring range	0...50 °C/-35...35 °C
Measuring accuracy at DC 24 V in the range of 20...25 °C 15...35 °C -35...50 °C	±0.3 k (typical) ±0.6 k ±1 k
Time constant t_{63}	< 3.5 min in 2 m/s moved air
Output signal, linear (terminal X3)	<ul style="list-style-type: none"> DC 0...10 V or DC 0...5 V $\hat{=}$ 0...50 °C/-35...35 °C, max. ±1 mA 4...20 mA $\hat{=}$ 0...50 °C/-35...35 °C, max. 500 ohm

Functional data (humidity with QSM2162)	
Range of use	5...95 % r.h. (non-condensing)
Measuring range	0...100 % r.h.
Measuring accuracy at 23 °C and DC 24 V 0...95 % r.h. 30...70 % r.h.	±5 % r.h. ±3 % r.h. (typical)
Time constant t_{63}	Approx. 20 s
Output signal, linear (terminal X2)	<ul style="list-style-type: none"> DC 0...10 V or DC 0...5 V $\hat{=}$ 0...100 % r.h., max. ±1 mA 4...20 mA $\hat{=}$ 0...100 % r.h., max. 500 ohm

Functional data	
Max. air velocity V_{max}	10 m/sec

Ambient conditions and protection classification	
Protection degree of housing	IP54 as per EN 60529 in built-in state
Protection class	III as per EN 60730-1
Environmental conditions	
Transport	IEC 60721-3-2
• Climatic conditions	Class 2K3
– Temperature	-25...70 °C
– Humidity	< 95 % r.h.
• Mechanical conditions	Class 2M2
Operation	IEC 60721-3-3
• Climatic conditions	Class 3K5
– Temperature (housing with electronics)	-5...45 °C
– Humidity	5...95 % r.h. (non-condensing)
• Mechanical conditions	Class 3M2

Standards, directives and approvals	
Product standard	EN 60730-1, EN 60730-2-9, EN 61000-6-2, EN 61000-6-3 Automatic electrical controls for household and similar use
Electromagnetic compatibility (applications)	For use in residential, commerce, light-industrial and industrial environments
EU conformity (CE)	A5W00096641 *)
RCM conformity	A5W00096643 *)
Environmental compatibility	The product environmental declaration (A5W00099435 *) contains data on environmentally compatible product design and assessments (RoHS compliance, materials composition, packaging, environmental benefit,

Standards, directives and approvals	
	disposal).

General	
Cable lengths for measuring signals Perm. cable lengths	See device data sheet for signal handling
Electrical connections screw terminals	1 × 2.5 mm ² or 2 × 1.5 mm ²
Materials and colors	
Base	Polycarbonate, RAL 7001 (silver-gray)
Cover	Polycarbonate, RAL 7035 (light-gray)
Immersion rod	ABS, RAL 7001 (silver-gray)
Filter cap	Polycarbonate, RAL 7001 (silver-gray)
Mounting flange	PA 66 – GF35 (black)
Cable entry gland	PA, RAL 7035 (light-gray)
Sensor (complete assembly)	Silicone-free
Packaging	Corrugated cardboard
Weight including package	
QSM2100	344.4 g
QSM2162	356 g
AQS2100	59 g

*) The documents can be downloaded from <http://siemens.com/bt/download>.

**) For detailed information on data update intervals, see Sensor data refresh frequency [→ 6].

Connection terminals

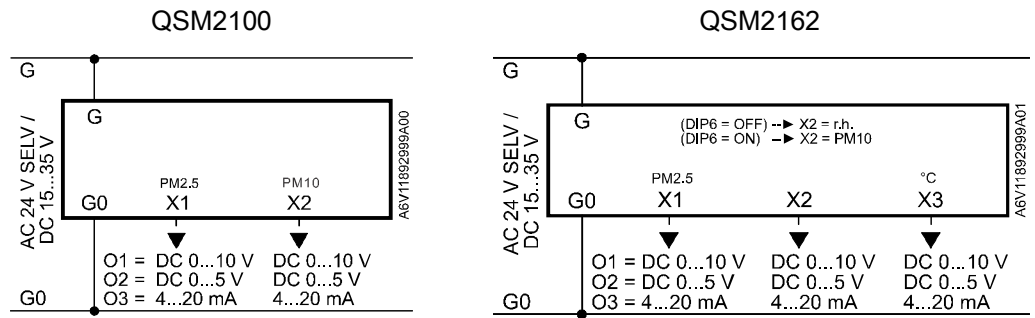

- G Operating voltage AC 24 V (SELV) or DC 15...35 V
- G0 Ground and measuring neutral
- X1 Signal output DC 0...10 V, DC 0...5 V or 4...20 mA
- X2 Signal output DC 0...10 V, DC 0...5 V or 4...20 mA
- X3 Signal output DC 0...10 V, DC 0...5 V or 4...20 mA

Dimensions

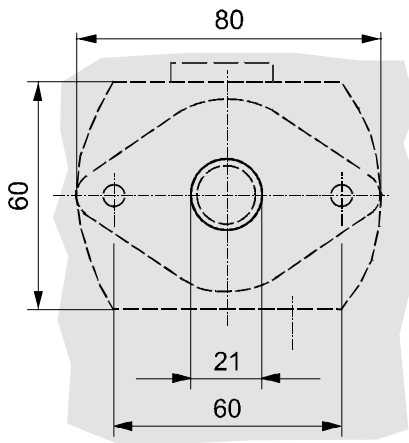
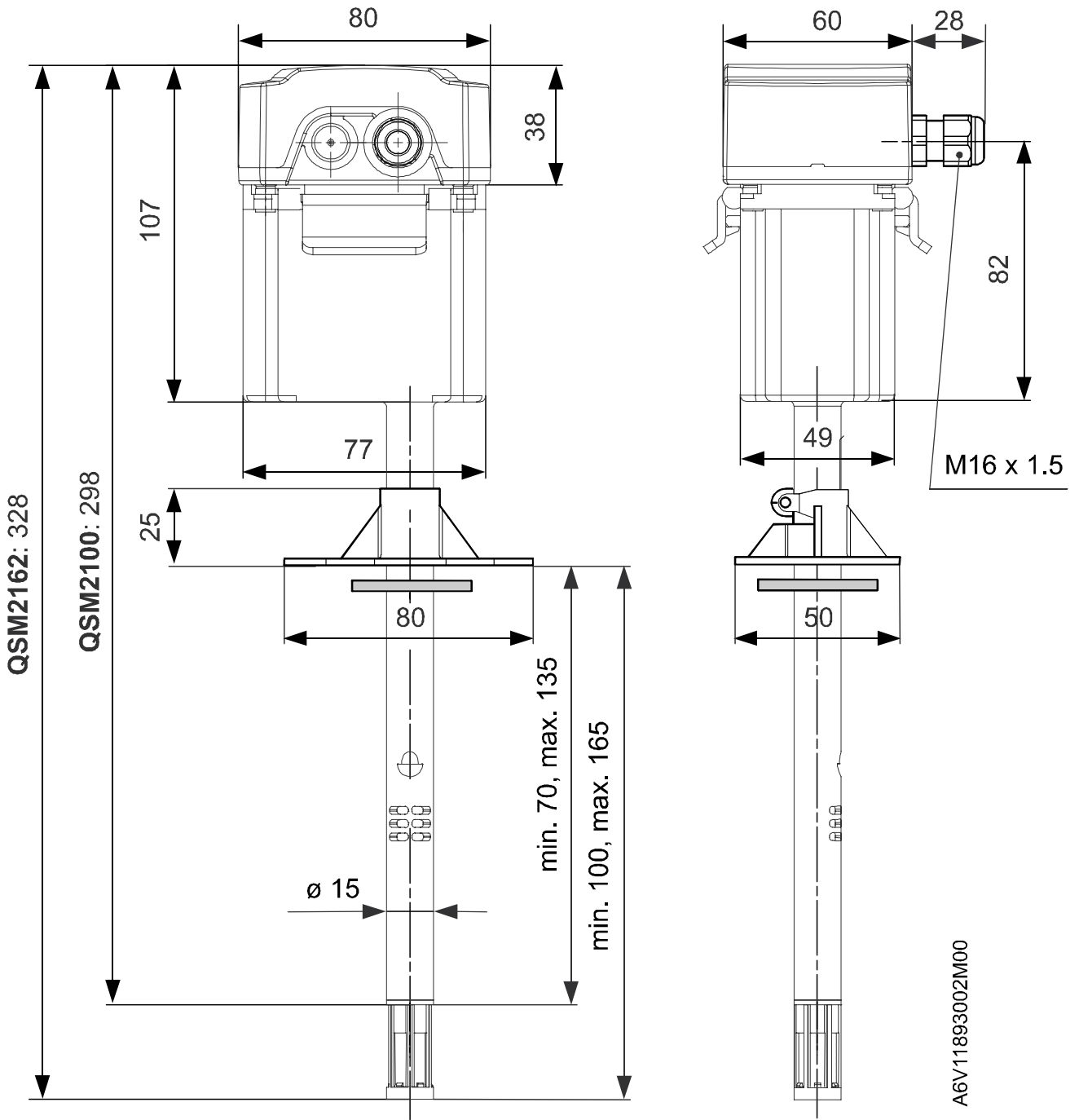

Dimensions in mm

Issued by
Siemens Switzerland Ltd
Smart Infrastructure
Global Headquarters
Theilerstrasse 1a
CH-6300 Zug
Tel. +41 58 724 2424
www.siemens.com/buildingtechnologies

© Siemens Switzerland Ltd, 2020
Technical specifications and availability subject to change without notice.