

MASTECH® MS2000G

DIGITAL AC/DC CLAMP METER USER'S MANUAL

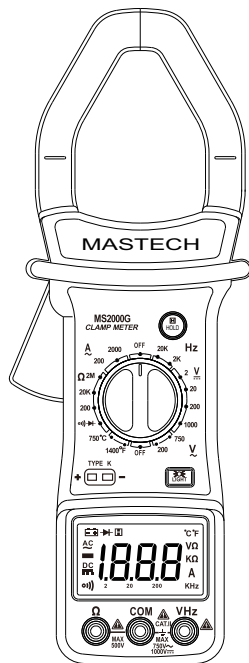

MASTECH®





CONTENTS

SAFETY INFORMATION	2
SAFETY SYMBOLS	2
SAFETY PRECAUTIONS	3
MAINTENANCE	4
GENERAL DESCRIPTION	4
FRONT PANEL DESCRIPTION	5
OPERATING INSTRUCTIONS	8
SPECIFICATIONS	11
REPLACING THE BATTERY	12
ACCESSORIES	13

SAFETY INFORMATION

The digital clamp meter has been designed according to IEC1010 – 1 and IEC1010 – 2 – 032 concerning safety requirements for electrical measuring instruments and hand – held current clamps with an overvoltage category (CAT II) and pollution 2.

SAFETY SYMBOLS

	Note-Important safety information, refer to the instruction manual.
	Caution, possibility of electric shock
	Equipment protected throughout by double insulation or reinforced insulation.
	Earth (ground) TERMINAL

CAT II: MEASUREMENT CATEGORY II is applicable to test and measuring circuits connected directly to utilization points (socket outlets and similar points) of the low-voltage MAINS installation.

The digital clamp meter complies with the requirements of the following European Community Directives: 89/336/EEC (Electromagnetic Compatibility) and 73/23/EEC (Low Voltage) as amended by 93/68/EEC (CE Marking).

However, electrical noise or intense electromagnetic fields in the vicinity of the equipment may disturb the measurement circuit. Measuring instruments will also

respond to unwanted signals that may be present within the measurement circuit.

Users should exercise care and take appropriate precautions to avoid misleading

SAFETY PRECAUTIONS

Follow all safety and operating instructions to ensure maximum personal safety during the operation and to ensure the meter is used safely and is kept in good operating condition.

- Read these operating instructions thoroughly and completely before operating your meter. Pay particular attention to WARNINGS, which will inform you of potentially dangerous procedures. The instructions in these warnings must be followed.
- Always inspect your meter and test leads for any sign of damage or abnormality before every use. If any abnormal conditions exist (i.e. broken test leads, cracked cases, display not reading, etc.), do not attempt to take any measurements.
- Do not expose the instrument to direct sunlight, extreme temperature or moisture.
- Never ground yourself when taking electrical measurements. Do not touch exposed metal pipes, outlets, fixtures, etc., which might be at ground potential. Keep your body isolated from ground by using

MASTECH®

dry clothing; rubber shoes, rubber mat, or any approved insulating material.

- You always are careful when working with voltages above 60V dc or 30V ac rms. Keep fingers behind the probe barriers while measuring.
- Never use the meter to measure voltages that might exceed the maximum allowable input value of any function.
- Never touch exposed wiring, connections or any live circuit when attempting to take measurements.

MAINTENANCE

- Before opening the case, always disconnect test leads from all energized circuits.
- Never use the meter unless the back cover is in place and fastened completely.
- Do not use abrasives or solvents on the meter. To clean it using a damp cloth and mild detergent only.
- Qualified and trained service technicians should only perform calibration and repair of the meter.
- Do not attempt calibration or service unless trained and another person capable of rendering first aid and resuscitation is present.

GENERAL DESCRIPTION

The meter is a handheld 3 1/2 digital clamp meter for

MASTECH®

measuring DC and AC voltage, AC current, Resistance, Frequency, Temperature (°C&°F), Diode and Continuity Test with battery operated.

FRONT PANEL DESCRIPTION

- (1) Transformer jaws
Pick up the AC current flowing through the conductor.
- (2) Hold button
When this button is pushed, the display will keep the last reading and “ **H** ” symbol will appear on the LCD until pushing it again.
- (3) Rotary switch
This switch is used to select functions and desired ranges as well as to turn on/off the meter.
- (4) Backlight
To use this function, press the Back light button. When this button is pushed, the Back light of display is on. After about 3 - 5 seconds, the Back light is self-off. The Back light is on again, just push this button once.
- (5) Display
3 1/2 digit, 7 segment, 18mm high, LCD.
- (6) “VHz” jack
This is positive input terminal for VOLT measurements connection is made to it using the red

MASTECH®

test lead.

(7) "COM" jack

This is negative (ground) input terminal for all measurement modes except current. Connection is made to it using the black test lead.

(8) "Ω" jack

This is the positive input terminal for ohms. Connection is made to it using the red test lead.

(9) Temperature Measuring Socket

Insert a "K" type thermocouple into the temperature measuring socket and contact the object to be measured with the thermocouple probe.

(10) Trigger

Press the lever to open the transformer. When the lever is released, the jaws will close again.

MASTECH®

CLAMP METER LAYOUT

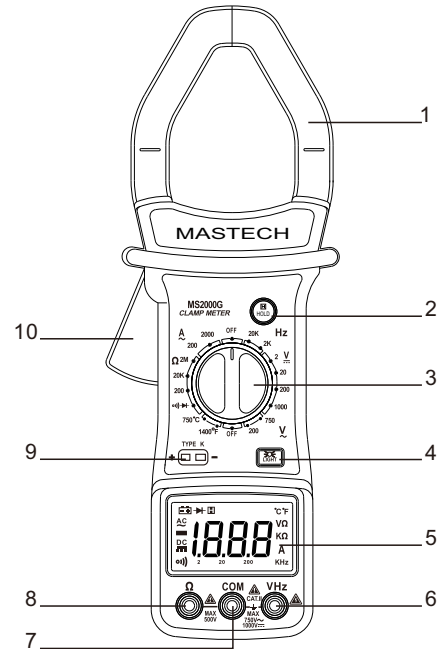

MASTECH®

OPERATING INSTRUCTIONS

DC VOLTAGE MEASUREMENT

1. Connect the red test lead to the "VHz" jack and the black lead to the "COM" jack.
2. Set rotary switch at desired V $\overline{\text{m}}$ position.
3. Connect test leads across the source or load being measured.
4. Read voltage value on the LCD display along with the polarity of the red lead connection.

AC VOLTAGE MEASUREMENT

1. Connect the red test lead to "VHz" jack and the black test lead to the "COM" jack.
2. Set the rotary switch at desired V~ position.
3. Connect test leads across the source or load being measured.
4. Read voltage value on the LCD display.

AC CURRENT MEASUREMENT

1. Set the rotary switch at desired A~ position.
2. Press the trigger to open transformer jaw and to clamp one conductor only, making sure that the jaw is firmly closed around the conductor.
3. Read current value on LCD display.

RESISTANCE MEASUREMENT

MASTECH®

1. Connect the red test lead to "Ω" jack and black test lead to the "COM" jack. (The polarity of red lead is positive "+".)
2. Set the rotary switch at desired "Ω" range position.
3. Connect test leads across the resistor to be measured and read LCD display.
4. If the resistance being measured is connected to a circuit, turn off power and discharge all capacitors before applying test probes.

NOTE:

1. If the resistance being measured exceeds the maximum value of the range selected or the input is not connected, an overrange indication "1" will be displayed.
2. When checking in-circuit resistance, be sure the circuit under test has all power removed and that all capacitors have been discharged fully.
3. For measuring resistance above 1MΩ, the meter may take a few seconds to get stable reading. This is normal for high resistance measurements.

MEASURING TEMPERATURE

1. Set the rotary switch at °C or °F Position. The LCD display will show the current environment temperature.

MASTECH®

2. Inserts “K” type thermocouple into the temperature measuring socket on the front panel and contact the object to be measured with the thermocouple probe.
3. Read temperature value on the LCD display.

WARNING

1. To avoid electric shock, be sure the thermocouple has been removed before changing to another function measurement.
2. Before attempting to insert thermocouple for testing, always be sure that test leads have been disconnected from any measurement circuits.
3. The thermocouple has been removed when making voltage measurements with test leads.

MEASURING FREQUENCY

1. Connect red test lead to the “VHz” jack and the black test to the COM jack.
2. Set the rotary switch at Hz Position.
3. Connect test leads across the source or load under measurement.

NOTE:

1. DO not apply more than 250Vrms to the input.
2. In noisy environment, it is preferable to use shield cable for measuring small signal.

DIODE TEST

1. Connect the red test lead to “Ω” jack and the black test lead to the “COM” jack (The polarity of red lead

MASTECH®

- is positive “+”).
2. Set the rotary switch at “▶” position.
 3. Connect the red test lead to the anode of the diode to be tested and the black test lead to the cathode of the diode.
 4. The approx. forward voltage drop of the diode will be displayed. If the connection is reversed, only figure “1” will be shown.

AUDIBLE CONTINUITY TEST

1. Connect red test lead to “Ω” jack, black test lead to “COM” jack.
2. Set range switch to “ⓘ” position.
3. Connect test leads to two points of circuit to be tested. If continuity exists, built-in buzzer will sound.

SPECIFICATIONS

Accuracy is specified for a period of one year after calibration and at 18°C to 28°C (64°F to 82°F) with relative humidity to 80%.

GENERAL

Maximum voltage between terminals and earth ground:	CAT II 1000V dc or 750V ac rms. (sine)
Display	LCD, 1999 counts, updates 2-3/ sec.

MASTECH®

Polarity indication	"-"displayed for negative polarity
Overrange Indication	Only figure "1" on the display
Jaw opening capability	55mm (Max conductor size)
Power	9V battery, NEDA 1604 or IEC 6F22
Low battery indication	"  " appears on the display
Operating Environment	0 to 40°C
Storage temperature	-10°C to 50°C
Temperature coefficient	0.1×specified accuracy) / °C (<18°C or >28°C)
Altitude	2000m
Size	282mm×104mm×47mm
Weight	Approx.570g.

DC VOLTAGE

Range	Resolution	Accuracy
2V	1mV	±0.5% of rdg ± 1 digit
20V	10mV	
200V	0.1V	
1000V	1V	±1.0% of rdg ± 2 digit

Input Impedance: 10MΩ

MASTECH®

AC VOLTAGE

Range	Resolution	Accuracy
200V	0.1V	±1.0% of rdg ± 3 digit
750V	1V	

Input Impedance: 10MΩ

Frequency range: 40Hz to 400Hz.

Response: Average responding, calibrated in rms. of sine wave.

AC CURRENT

Range	Resolution	Accuracy
200A	0.1A	±2.0% of rdg ± 5 digit
2000A	1A	<600A ±2.0% of rdg ± 5 digits
		600A to 1000A ±3.0% of rdg ± 5 digits
		>1000A ±3.0% of rdg ± 15 digits

Overload Protection: 2200A for 60 seconds maximum.

Frequency range: 50Hz to 60Hz.

RESISTANCE

Range	Resolution	Accuracy
200Ω	0.1Ω	±1.0% of rdg ± 3 digit
20kΩ	10Ω	±1.5% of rdg ± 15 digit
2MΩ	1kΩ	±1.5% of rdg ± 15 digit

MASTECH®

TEMPERATURE



Range	Resolution	Test Range	Accuracy
0°C to 750°C	1°C	0°C to 400°C	±1.0% of rdg ± 3 °C
		400°C to 750°C	±2.0% of rdg ± 1 °C
32°F to 1400°F	1°F	32°F to 752°F	±1.0% of rdg ± 3 °F
		752°F to 1400°F	±2.0% of rdg ± 1 °F

FREQUENCY

Range	Resolution	Accuracy
2kHz	1Hz	±2.0% of rdg ± 5 digit
20kHz	10Hz	±1.5% of rdg ± 5 digit

Input Limit: 250V ac.

DIODE & CONTINUITY

Range	Description
	Display read approximate forward voltage of diode.
	If continuity exists (about less than 30Ω), built-in buzzer will sound.

REPLACING THE BATTERY



WARNING

Before attempting to open the case of battery, always be sure that test leads have been disconnected from measurement circuits. Close case and tighten screws completely before using the meter to avoid electrical shock hazard.

If “” appears on display, it indicates that the battery should be replaced. Use the following procedure to replacing the battery:

1. Disconnect test leads from any live source, turn the rotary switch to OFF, and remove the test leads from the input terminals.
2. The battery cover is secured to the bottom case by a screw. Using a screwdriver, remove the screw from the battery cover and remove the battery cover.
3. Remove battery and replace with a new equivalent 9 volt battery.
4. Replace the battery cover and reinstall the screw.

ACCESSORIES

- | | |
|--|---------------------|
| • Operator's instruction manual | • Set of test leads |
| • “K” type thermocouple | • Gift box |
| • 9 volt battery. NEDA 1604 6F22 006P type | |

CAUTION:

Using this appliance in an environment with a strong radiated radio-frequency electromagnetic field (approximately 3V/m), may influence its measuring accuracy. The accuracy can be reduced to ±(12% of reading + 6 digits).

Replacing Test Leads

Replace test leads if leads become damaged or worn.

WARNING

Use meet EN 61010-031 standard, rated CAT II 1000V, or better test leads.

