

MASTECH®

MS2160

DIGITAL CLAMP METER User's Manual

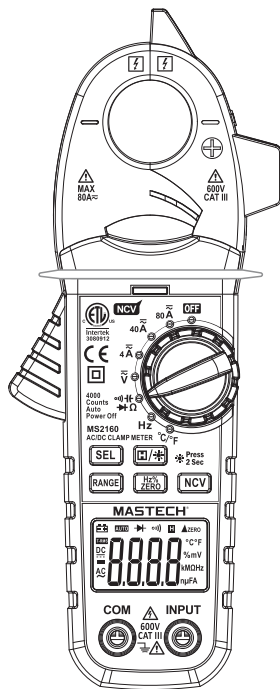

Intertek



CONTENTS

1. Safety Information	1
1.1 Preparation.....	1
1.2 During Use.....	1
1.3 Safety Symbols.....	3
1.4 Maintenance.....	3
2. Instrument Description	4
2.1 Front Panel	4
2.2 LCD Display	6
3. Specifications	6
3.1 General Specifications	6
3.2 Technical Specifications.....	7
4. Operating Instructions	12
4.1 Reading Hold.....	12
4.2 Relative Mode.....	12
4.3 Frequency/Duty Cycle Switch.....	13
4.4 Manual Range	13
4.5 Switching Functions.....	13

CONTENTS

4.6 Back light/Clamp light.....	13
4.7 Auto Power Off.....	14
4.8 Preparing for Measurement	14
4.9 AC/DC Current.....	15
4.10 AC Voltage.....	15
4.11 DC Voltage.....	16
4.12 Frequency/Duty Cycle.....	17
4.13 Resistance.....	18
4.14 Diode.....	19
4.15 Capacitance.....	19
4.16 Continuity.....	20
4.17 Temperature.....	20
4.18 Non-Contact Voltage (NCV).....	21
5. Maintenance	21
5.1 Replacing the Batteries.....	21
5.2 Replacing the Test Leads.....	22
6. Accessories	22

1. Safety Information

Warning

Read and follow all safety guidelines outlined in this manual before use to prevent personal injury or damage to the meter.

This meter meets GB/T 13978-92 digital multimeter general specifications in accordance with GB4793.1-1995 (EN61010-1, EN61010-2-032) safety requirements for electronic measuring instruments with and over-voltage category of CAT III 600V and pollution degree of 2.

Follow all safety instructions to ensure safe usage of the meter.

Proper usage and protection will ensure a long life of the meter.

1.1 Preparation

1.1.1 When using the meter, users must follow standard safety rules:

- Use protection against electrical shock
- Do not misuse the instrument

1.1.2 Check the meter for damage during transport

1.1.3 Check the test leads for damage to the insulation or wires before use.

1.1.4 Only use the test leads provided with the meter. Replace only with similar leads with matching specifications.

1.2 During Use

1.2.1 Always select the proper function and range before measurement.

1.2.2 Never exceed the protection limit values indicated in the specifications for each range of measurement.

1.2.3 Do not measure voltages that exceed 600V between terminals and earth ground.

1.2.4 Always be careful when working with voltages above 60V dc or 30V ac rms. Keep fingers behind the probe barriers when making voltage measurements.

1.2.5 Choose the highest range when the value to be measured is unknown beforehand.

1.2.6 Disconnect leads from circuit before switching functions/ranges.

1.2.7 Turn off power and discharge capacitors before measuring resistance, capacitance, diodes or continuity.









1.2.8 Do not connect the meter to a voltage source while in current, resistance, capacitance, diode or continuity modes.

1.2.9 Do not place the meter in any environment with high pressure, high temperature, dust, explosive gas or vapor.

1.2.10 Ensure the meter works properly by testing a known voltage source first. If not working properly, the protective equipment may be damaged; have the meter serviced before using.

1.2.11 Do not use the meter with the battery cover not securely in place.

1.3 Safety Symbols

	Note-Important safety information, refer to the instruction manual.
	Application around and removal from UNINSULATED HAZARDOUS LIVE conductors is permitted.
	Caution, possibility of electric shock
	Equipment protected throughout by double insulation or reinforced insulation.
	Conforms to UL STD. 61010-1, 61010-2-032, 61010-2-033; Certified to CSA STD C22.2 NO. 61010-1, 61010-2-032, 61010-2-033
	Complies with European (EU) safety standards
	Earth (ground) TERMINAL
	Direct current
	Alternating current

CAT III: MEASUREMENT CATEGORY III is applicable to test and measuring circuits connected to the distribution part of the building's low-voltage MAINS installation.

1.4 Maintenance

- 1.4.1 Maintenance/calibration should only be performed by professionals.
- 1.4.2 Before opening the case, always disconnect test leads from all energized circuits.
- 1.4.3 When the " "symbol appears, replace the batteries to avoid incorrect readings.
- 1.4.4 Clean meter with a damp cloth and mild detergent; do not use chemical solvents on the meter.
- 1.4.5 Turn the rotary switch to the OFF position when the meter is not in use.

- 1.4.6 If the meter is not going to be used for an extended period of time, remove the batteries and avoid storing in a hot/humid environment.

2. Instrument Description

- This meter is a portable, professional instrument with a digital LCD display with back-light for easy reading. Easy to use with one hand with overload protection and low battery indication. Ideal for professionals, educational or home use.
- Functions include: AC/DC current, AC/DC voltage, resistance, capacitance, continuity, diodes, frequency, duty cycle, and temperature.
- Auto-range function
- Display hold
- Avg. responding for AC current/voltage
- Non-contact voltage measurement
- Frequency measurement through clamp
- Automatic power off feature

2.1 Front Panel

1. Current clamp head
2. NCV indicator
3. Function buttons
4. LCD screen
5. Voltage, resistance, capacitance, frequency, diode, continuity and temperature input jack
6. Common input
7. Rotary switch
8. Clamp center indicator
9. NCV sensor

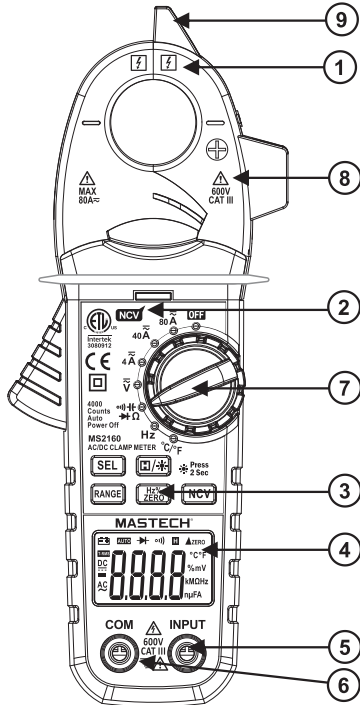

2.2 LCD Display

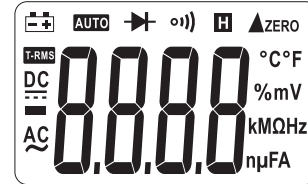

3. Specifications

Meter should be calibrated annually at 18°C~28°C with a relative humidity of <80%.

3.1 General Specifications

Auto-range	yes
Overload protection	(CAT III 600V)
Max. voltage between terminals and earth ground:	600V DC or AC
Operating altitude	<2000m
Display	3 ¾ digit LCD display;
max. reading:	4000
Polarity Indication	display automatically shows “-”
Over-range Indication	display shows “OL” or “-OL”
Power	3x 1.5V AAA Batteries
Low Battery Indication	“  ” will appear on the display.

MASTECH®

Temperature coefficient	less than 0.1 x accuracy/°C
Operating temperature	18°C~28°C
Storage temperature	-10°C~50°C
Dimensions	195x80x45mm
Weight	approx. 195g (including battery)

3.2 Technical Specifications

3.2.1 AC Current

Range	Resolution	Accuracy
4A	1mA	±(2.5% of reading +5 digits)
40A	10mA	
80A	100mA	

- Max. input current: 80A AC
- Frequency range: 40~400Hz

3.2.2 DC Current

Range	Resolution	Accuracy
4A	1mA	±(2.5% of reading +5 digits)
40A	10mA	
80A	100mA	

- Max. input current: 80A DC

MASTECH®

3.2.3 DC Voltage

Range	Resolution	Accuracy
4V	0.001V	±(0.8% of reading +3 digits)
40V	0.01V	
400V	0.1V	
600V	1V	

- Input impedance: 10MΩ
- Max input voltage: 600V DC

Note:

At small voltage ranges, unsteady readings will appear before the test leads make contact with the circuit. This is normal since the meter is highly sensitive. When the test leads are connected to the circuit, the true reading will be shown.

3.2.4 AC Voltage

Range	Resolution	Accuracy
4V	0.001V	±(1.0% of reading +3 digits)
40V	0.01V	
400V	0.1V	
600V	1V	

- Input impedance: 10MΩ
- Max input voltage: 600V AC rms
- Frequency range: 40~400Hz

Note:

At small voltage ranges, unsteady readings will appear before the test leads make contact with the circuit. This is normal since the meter is highly sensitive. When the test leads are connected to the circuit, the true reading will be shown.

3.2.5 Frequency

3.2.5.1 Hz position

Range	Resolution	Accuracy
9.999Hz	0.001Hz	±(0.5% of reading +3 digits)
99.99Hz	0.01Hz	
999.9Hz	0.1Hz	
9.999kHz	0.001kHz	
99.99KHZ	0.01kHz	
999.9KHZ	0.1KHZ	
9.999MHZ	0.001MHZ	

3.2.5.2 A position (Clamp)

Range	Resolution	Accuracy
99.99Hz	0.01Hz	±(1.5% of reading +5 digits)
999.9Hz	0.1Hz	
9.999kHz	1Hz	

- Frequency range: 40~10kHz
- Input signal range: ≥1AAC rms. As current increases, frequency increases as well.
- Max. input current: 80AAC

3.2.5.3 V position

Range	Resolution	Accuracy
99.99Hz	0.001Hz	±(1.5% of reading +5 digits)
999.9Hz	0.01Hz	
9.999kHz	0.1Hz	

- Frequency range: 40~10kHz
- Input signal range: ≥0.2V AC rms. As current increases, frequency increases as well.
- Input impedance: 10MΩ
- Max input voltage: 600V DC/ AC rms

3.2.6 Duty Cycle

Range	Resolution	Accuracy
0.5 – 99.5%	0.1%	±3.0%

3.2.6.1 Hz Position

- Frequency range: 40~10MHz
- Input signal range: ≥2V AC rms. As voltage increases, frequency increases as well.
- Max input voltage: 250V AC rms

3.2.6.2 A position (Clamp)

- Frequency range: 40~1kHz
- Input signal range: ≥4AAC rms. As current increases, frequency increases as well.
- Max. input current: 80AAC

3.2.6.3 V position

- Frequency range: 40~10kHz
- Input signal range: ≥0.6V AC rms. As voltage increases, frequency increases as well.
- Input impedance: 10MΩ
- Max input voltage: 600V AC rms

3.2.7 Resistance

Range	Resolution	Accuracy
400Ω	0.1Ω	±(0.8% of reading +3 digits)
4kΩ	0.001kΩ	
40kΩ	0.01kΩ	
400kΩ	0.1kΩ	
4MΩ	0.001MΩ	
40MΩ	0.01MΩ	±(1.2% of reading +3 digits)

- Open circuit voltage: 1V
- Overload protection: 250V DC/AC rms

3.2.8 Continuity

Range	Resolution	Accuracy
•)	0.1Ω	If the measured resistance is less than 50Ω, the buzzer will sound.

- Overload protection: 250V DC/AC rms

3.2.9 Capacitance

Range	Resolution	Accuracy
4nF	0.001nF	±(4.0% of reading +3 digits)
40nF	0.01nF	
400nF	0.1nF	
4μF	0.001F	
40μF	0.01μF	
400μF	0.1μF	
4mF	0.001mF	
40mF	0.01mF	

- Overload protection: 250V DC/AC rms

3.2.10 Diode

Range	Resolution	Accuracy
▶+	0.001V	Shows approx. forward voltage drop of a diode

- Shows approx. forward voltage drop of a diode



3.2.11 Temperature

Range	Resolution	Accuracy
-20°C~1000°C	1°C	±(3.0% of reading +3 digits)
-4°F~1832°F	1°F	±(3.0% of reading +3 digits)



- Overload protection: 250V DC/AC rms

4. Operating Instructions

4.1 Reading Hold

- 4.1.1 To hold a reading on the display, press  and the current reading will be held on the display.
- 4.1.2 Press  to release the hold and return to normal display.





4.2 Relative Mode

- 4.2.1 Relative mode is only available for DC voltage, DC current, and capacitance measurements.
- 4.2.2 Press  to enter relative mode; auto-range is disabled. The display will show the value measured compared to the value when the button was pressed. Press  again to return to normal display.

Note:

When using relative mode, select the appropriate range by pressing  before activating relative mode.



4.3 Frequency/Duty Cycle Switch

4.3.1 In AC current or AC voltage modes, press  to enter frequency mode. Press  in frequency mode to enter duty cycle mode. Press  in duty cycle mode to return to normal display. Pressing  while the rotary switch is in the “Hz” position will switch between frequency and duty cycle.



4.4 Manual Range

4.4.1 The meter’s default range is “AUTO.” To select manual range, press  to enter manual range. Each press of the button increases the range and returns to the lowest range when pressed at the highest range. Hold the button to return to auto-range. Manual range cannot be used in current, frequency, duty cycle, diode, continuity, or temperature modes.



4.5 Switching Functions

- 4.5.1 In current and voltage positions, press  to switch between AC and DC modes.
- 4.5.2 In the multifunction position, press  to switch between resistance, capacitance, continuity, and diode modes.
- 4.5.3 In the temperature position, press  to switch between Celsius and Fahrenheit modes.

4.6 Back light/Clamp light

- 4.6.1 For making measurements in dark areas, hold  and the back light and clamp light will turn on for 15 seconds before turning off.
- 4.6.2 Hold  while the back light/clamp light is on to turn it off manually.
- 4.6.3 The back light and clamp light requires a large operating current, so use sparingly.



Note:

When the battery voltage drops below 3.6V the display shows  symbol. Sometimes when the back light is turned on, the  symbol will appear because of the large working current needed. The batteries do not need to be replaced until the symbol appears without the backlight on.

4.7 Auto Power Off

- 4.7.1 After 15 minutes of non-use the meter will turn itself off. 1 min. before auto off the meter will beep 5 times, then sound a long beep as the meter turns off.
- 4.7.2 To turn the meter back on after auto off, press any button.
- 4.7.3 Hold  when turning on the meter to turn off the auto power off feature.



4.8 Preparing for Measurement

- 4.8.1 Turn the rotary switch to turn on the meter. If the battery voltage is less than 3.6V, the  symbol will appear. Replace the batteries before use.
- 4.8.2  symbol means the input signal should not exceed the limit indicated to protect the meter from damage.
- 4.8.3 Move the rotary switch to the correct measurement position and range.
- 4.8.4 When connecting test leads to a circuit, connect the common lead before the hot lead. When disconnecting, remove the hot lead before the common lead.



4.9 AC/DC Current

Warning

Electric shock hazard.
Remove test leads before measuring current.

- 4.9.1 Move the rotary switch to the proper current position; DC current is the default measurement. Press  to return the display to zero if necessary.
- 4.9.2 Hold the trigger and clamp one conductor to be measured.
- 4.9.3 Measurement will be shown on the display.
- 4.9.4 Press  to switch to AC current.
- 4.9.5 Clamp one conductor and the measurement will be displayed.
- 4.9.6 In DC current, observe the “+” and “-” symbols on the clamp indicating the direction of polarity for DC current flow.

Note:

1. Clamping more than one conductor will not produce correct readings.
2. Place the conductor in the center of the clamp for the most precise readings.
3. Press  in DC current before measurement to get the most accurate measurement.
4. “” indicates maximum input current is 80A DC/AC (non-rms).

4.10 AC Voltage

Warning

Electric shock hazard.
Use caution to avoid damage or personal injury.
Maximum input voltage: 600V AC rms

- 4.10.1 Turn the rotary switch to the voltage position. Press  to switch to AC voltage.
- 4.10.2 Connect the red test lead to the INPUT jack and the black test lead to the COM jack.
- 4.10.3 Connect the test leads in parallel to the circuit under test.
- 4.10.4 Read the measured voltage on the display.

Note:

1. In small voltage ranges, the display may show a reading before leads are connected. This is normal because of the high sensitivity of the meter. Once the leads are connected to a circuit, the true voltage will be displayed.
2. “” indicates maximum input voltage is 600V AC (non-rms).
3. If measured voltage is greater than 750V AC rms, the meter will sound an alarm.

4.11 DC Voltage

Warning

Electric shock hazard.
Use caution to avoid damage or personal injury.
Maximum input voltage: 600V DC.



- 4.11.1 Turn the rotary switch to the voltage position. The default setting is DC voltage.
- 4.11.2 Connect the red test lead to the INPUT jack and the black test lead to the COM jack.
- 4.11.3 Connect the test leads in parallel to the circuit under test.
- 4.11.4 Read the measured voltage on the display.

Note:

1. In small voltage ranges, the display may show a reading before leads are connected. This is normal because of the high sensitivity of the meter. Once the leads are connected to a circuit, the true voltage will be displayed.
2. “” indicates maximum input voltage is 600V DC.
3. If measured voltage is greater than 1000V DC, the meter will sound an alarm.

4.12 Frequency/Duty Cycle



4.12.1 Hz position

- 4.12.1.1 Turn the rotary switch to the Hz position to measure frequency.
- 4.12.1.2 Press  to switch to duty cycle. Press  again to switch back to frequency.

4.12.2 A position (clamp)

Warning

**Electric shock hazard.
Remove test leads before measuring current.**

- 4.12.2.1 Turn the rotary switch to one of the current positions.
- 4.12.2.2 Hold the trigger and clamp one conductor to be measured.
- 4.12.2.3 Press  to switch to frequency measurement. Press  again to switch to duty cycle.

Note:



1. Clamping more than one conductor will not produce correct readings.
2. Frequency range is 10Hz~10kHz. Frequencies outside this range are possible to be measured, but the meter cannot guarantee the accuracy of these measurements.

3. “” indicates maximum input current is 80A DC/AC (non-rms).

4.12.3 V position

Warning

**Electric shock hazard.
Use caution to avoid damage or personal injury.
Maximum input voltage: 600V AC rms.**

- 4.12.3.1 Turn the rotary switch to the voltage position. Press to switch to AC voltage.
- 4.12.3.2 Connect the red test lead to the INPUT jack and the black test lead to the COM jack.
- 4.12.3.3 Press  to switch to frequency measurement. Press  again to switch to duty cycle.
- 4.12.3.4 Connect the test leads in parallel to the circuit under test.
- 4.12.3.5 Read the measured voltage on the display.

Note:

1. Frequency range is 10Hz~10kHz. Frequencies outside this range are possible to be measured, but the meter cannot guarantee the accuracy of these measurements.
2. “” indicates maximum input voltage is 600V AC (non-rms).

4.13 Resistance

Warning

**Electric shock hazard.
Turn off all power and discharge all capacitors before making resistance measurements.**

- 4.13.1 Turn the rotary switch to the  position. The default setting is resistance.
- 4.13.2 Connect the red test lead to the INPUT jack and the black test lead to the COM jack.
- 4.13.3 Connect the test leads in parallel to the circuit under test.
- 4.13.4 Read the measured resistance on the display.

Note:

1. When the leads are not connected, the display will show "OL"
2. When the measured resistance is greater than 1M Ω , wait a few seconds for readings to stabilize. This is normal for high resistance measurements.

4.14 Diode

- 4.14.1 Turn the rotary switch to the $\rightarrow \Omega$ position. Press **[SEL]** 3 times to switch to diode mode.
- 4.14.2 Connect the red test lead to the INPUT jack and the black test lead to the COM jack.
- 4.14.3 Connect the red lead to the anode (+) and the black lead to the cathode (-) of the diode.
- 4.14.4 Read the measured voltage on the display.

Note:

1. The meter shows the approximate forward-biased voltage drop.
2. If the leads are not connected or reversed, the display will show "OL".

4.15 Capacitance

Warning

Electric Shock Hazard.
Turn off all power and discharge all capacitors before making capacitance measurements.

- 4.15.1 Turn the rotary switch to the $\rightarrow \Omega$ position. Press **[SEL]** once to switch to capacitance mode.
- 4.15.2 Connect the red test lead to the INPUT jack and the black test lead to the COM jack.
- 4.15.3 Connect the test leads to the capacitor to be measured.
- 4.15.4 Read the measured capacitance on the display.

Note:

1. When measuring large capacitances, wait a few seconds for readings to stabilize. This is normal for high capacitance measurements ($\geq 4\text{mF}$).
2. To improve the accuracy below 10nF measuring value, subtract the distributed capacitance of meter and cable.

4.16 Continuity

Warning

Electric Shock Hazard.
Turn off all power and discharge all capacitors before making continuity measurements.

- 4.16.1 Turn the rotary switch to the $\rightarrow \Omega$ position. Press **[SEL]** 2 times to switch to diode mode.
- 4.16.2 Connect the red test lead to the INPUT jack and the black test lead to the COM jack.
- 4.16.3 Connect the test leads to the circuit under test.
- 4.16.4 Read the measured resistance on the display.
- 4.16.5 If the measured resistance is less than 50 Ω , the buzzer will sound.

Note:

When the leads are not connected or if the measured resistance is $\geq 400\Omega$, the display will show "OL"

4.17 Temperature

- 4.17.1 Turn the rotary switch to the $^{\circ}\text{C}/^{\circ}\text{F}$ position. The default setting is $^{\circ}\text{C}$. Press **[SEL]** to switch to $^{\circ}\text{F}$ if necessary.
- 4.17.2 Connect the red (+) end of the type K thermocouple to the INPUT jack and the black (-) end to the COM jack.
- 4.17.3 Place the tip of the thermocouple on the surface of the object to be measured.
- 4.17.4 Read the measured temperature on the display.

4.18 Non-Contact Voltage (NCV)

Hold down the NCV button and move the tip of the clamp toward the conductor under test. If the detected voltage is $\geq 110V$ AC (rms), the NCV indicator will flash and the buzzer will beep.

Note:

1. Do not rely solely on NCV detection to determine the presence of voltage. Detection can be affected by socket design, insulation thickness, or other factors.
2. Interference from outside sources could accidentally trigger the NCV detector.

5. Maintenance

5.1 Replacing The Batteries

WARNING

To avoid electric shock, make sure that the test leads have been clearly moved away from the circuit under measurement before opening the battery cover of the meter.

WARNING

Do not mix old and new batteries. Do not mix alkaline, standard (carbon-zinc), or rechargeable (ni-cad, ni-mh, etc) batteries.

- 5.1.1 If the sign " " appears, it means that the batteries should be replaced.
- 5.1.2 Loosen the fixing screw of the battery cover and remove it.
- 5.1.3 Replace the exhausted batteries with new ones.
- 5.1.4 Put the battery cover back and fix it again to its origin form.

Note:

Do not reverse the polarity of the batteries.

5.2 Replacing Test Leads

Replace test leads if leads become damaged or worn.

WARNING

Use meet EN 61010-031 standard, rated CAT III 600V, or better test leads.

6. Accessories

1	Test Leads	Spec: 1000V, 10A	1 pair
2	User's Manual		1 piece
3	P3400 type-K thermocouple		1 piece
4	AAA batteries		3 piece



R-00-05-1123