

OPERATOR'S
INSTRUCTION MANUAL

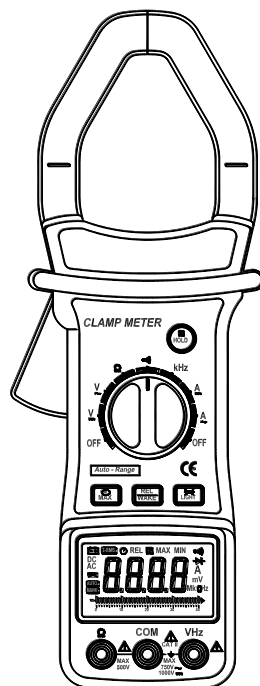

DIGITAL CLAMP METER

CONTENTS**PAGE**

Safety Information	1
Safety Symbols	1
Safety Precautions	2
Maintenance	4
General Description	4
Front Panel Description	4
Clamp Meter Layout	9
Operating Instructions	10
Specifications	13
Auto Power Off	17
Replacing The Battery	17
Accessories	18









 **CAUTION:**

Using this appliance in an environment with a strong radiated radio-frequency electromagnetic field (approximately 3V/m), may influence its measuring accuracy. The accuracy can be reduced to \pm (12% of reading + 6 digits).

SAFETY INFORMATION

The digital clamp meter has been designed according to IEC1010 – 1 and IEC1010 – 2 – 032 concerning safety requirements for electrical measuring instruments and hand – held current clamps with an overvoltage category (CAT II) and pollution 2.

SAFETY SYMBOLS

	Important safety information, refer to the operating manual.
	Dangerous voltage may be present.
	Earth ground.
	Double insulation (Protection class II).
	AC – Alternating Current.
	DC – Direct current.
	Battery.
	Conforms to European Union directives.

The digital clamp meter complies with the requirements of the following European Community Directives:

89/336/EEC (Electromagnetic Compatibility) and 73/23/EEC (Low Voltage) as amended by 93/68/EEC (CE Marking).

However, electrical noise or intense electromagnetic fields in the vicinity of the equipment may disturb the measurement circuit. Measuring instruments will also respond to unwanted signals that may be present within the measurement circuit.

Users should exercise care and take appropriate precautions to avoid misleading.

SAFETY PRECAUTIONS

Follow all safety and operating instructions to ensure maximum personal safety during the operation and to ensure the meter is used safely and is kept in good operating condition.

- Read these operating instructions thoroughly and completely before operating your meter. Pay particular attention to WARNINGS, which will inform you of potentially dangerous procedures.

The instructions in these warnings must be followed.

- Always inspect your meter and test leads for any sign of damage or abnormality before every use. If any abnormal conditions exist (i.e. broken test leads, cracked cases, display not reading, etc.), do not attempt to take any measurements.
- Do not expose the instrument to direct sunlight, extreme temperature or moisture.
- Never ground yourself when taking electrical measurements. Do not touch exposed metal pipes, outlets, fixtures, etc., which might be at ground potential. Keep your body isolated from ground by using dry clothing; rubber shoes, rubber mat, or any approved insulating material.
- You always are careful when working with voltages above 60V dc or 30V ac rms. Keep fingers behind the probe barriers while measuring.
- Never use the meter to measure voltages that might exceed the maximum allowable input value of any function.
- Never touch exposed wiring, connections or any live circuit when attempting to take measurements.

MAINTENANCE

- Before opening the case, always disconnect test leads from all energized circuits.
- Never use the meter unless the back cover is in place and fastened completely.
- Do not use abrasives or solvents on the meter. To clean it using a damp cloth and mild detergent only.
- Qualified and trained service technicians should only perform calibration and repair of the meter.
- Do not attempt calibration or service unless trained and another person capable of rendering first aid and resuscitation is present.

GENERAL DESCRIPTION

The meter is an autoranging professional clamp meter with digital and analog display, 3999 counts and 40 segment bar graph. For measuring DC and AC voltage, DC and AC current, Resistance, Frequency and Continuity Test with battery operated.

FRONT PANEL DESCRIPTION

- ① **Transformer jaws**
Pick up the AC or DC current flowing through the conductor.

① **Hold button**

When this button is pushed, the display will keep the last reading and “” symbol will appear on the LCD until pushing it again.

② **Rotary switch**

This switch is used to select functions and to turn on / off the meter.

③ **REL/WAKE button**

When measuring:

Press the button to select enter the relative measurement mode and the "REL" symbol will appear on LCD. Press the button again, the "REL" blink, the LCD shows the Input reading of REL function active. Push this button more than 1 seconds to disabled the function.

NOTE:

When press the button, the meter is converted to a fixation range. So the measuring range is the display current range.

After auto power off:

After auto power off, need pressing the button one time for waking it. **So the meter turn on.**

④ **LIGHT button**

To use this function, press this LIGHT button. When the button is pushed, the light of display is on. After about 3 – 5 seconds, the light is

self-off. The light is on again, just push this button once.

⑤ **“VHz” jack**

This is positive input terminal for volt and frequency measurement connection is made to it using the red test lead.

⑥ **“COM” jack**





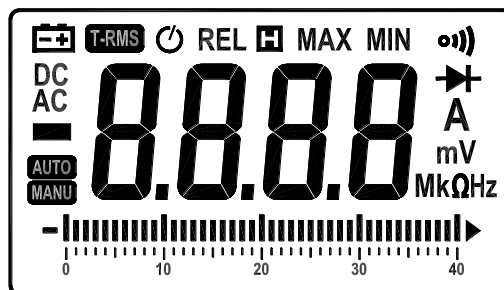

This is negative (ground) input terminal for all measurement modes except current. Connection is made to it using the black test lead.

⑦ **“Ω” jack**

This is the positive input terminal for ohms. Connection is made using the red test lead.

⑧ **LCD Display**



AUTO	Auto range indication.
MANU	fixation range indication
	Negative polarity indicates for digital reading.
AC	AC input indication
DC	DC input indication
	Low battery indication
T-RMS	True rms indication
	Auto power off indication
REL	Relative measurement indication
	Auto hold is active.
MAX	Maximum reading displayed.
MIN	Minimum reading displayed.
MAX MIN	Current value measurement indication
	Continuity beeper function indication.
	Testing diode mode
A	Current measurement indication
mV	Voltage measurement indication
MkΩ	Ohm measurement indication
kHz	Frequency measurement indication

⑨ **MAX button**

Press the button to select enter the Maximum value recording hold mode and the "MAX" symbol will appear on LCD.

" MAX MIN" blink is current value. When the meter operates in Maximum value recording hold mode, push this button more than 1 seconds to disabled the function.

NOTE:

When press the button, the meter is converted to a fixation range. So the measuring range is the display current range.

⑩ **Trigger**

Press the lever to open the transformer. When the lever is released, the jaws will close again.

CLAMP METER LAYOUT

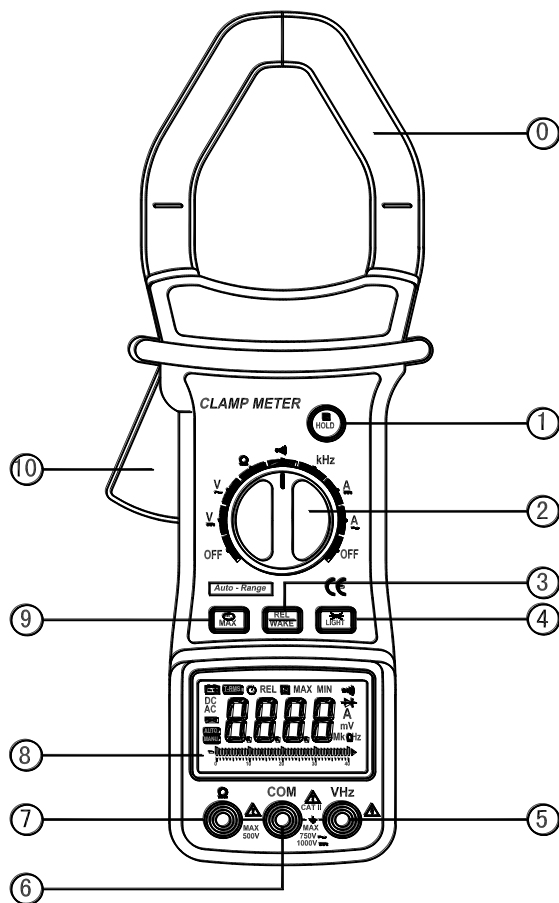

OPERATING INSTRUCTIONS

DC VOLTAGE MEASUREMENT

1. Connect the red test lead to the “VHz” jack and the black lead to the “COM” jack.
2. Set rotary switch at desired $V \text{---}$ position.
3. Connect test leads across the source or load being measured.
4. Read voltage value on the LCD display along with the polarity of the red lead connection.

AC VOLTAGE MEASUREMENT

1. Connect the red test lead to “VHz” jack and the black test lead to the “COM” jack.
2. Set the rotary switch at desired $V \sim$ position.
3. Connect test leads across the source or load being measured.
4. Read voltage value on the LCD display.

DC CURRENT MEASUREMENT

1. Set the rotary switch at desired $A \text{---}$ position.
2. Press the trigger to open transformer jaw and to clamp one conductor only, making sure that the jaw is firmly closed around the conductor.
3. Read current value on LCD display.

AC CURRENT MEASUREMENT

1. Set the rotary switch at desired A~ position.
2. Press the trigger to open transformer jaw and to clamp one conductor only, making sure that the jaw is firmly closed around the conductor.
3. Read current value on LCD display.

RESISTANCE MEASUREMENT

1. Connect the red test lead to “ Ω ” jack and black test lead to the “COM” jack (The polarity of red lead is positive “+”).
2. Set the rotary switch at desired “ Ω ” range position.
3. Connect test leads across the resistor to be measured and read LCD display.
4. If the resistance being measured is connected to a circuit, turn off power and discharge all capacitors before applying test leads.

NOTE:

1. If the resistance being measured exceeds the maximum value of the range selected or the input is not connected, an overrange indication “OL” will be displayed.

2. When checking in-circuit resistance, be sure the circuit under test has all power removed and that all capacitors have been discharged fully.
3. For measuring resistance above $1\text{M}\Omega$, the meter may take a few seconds to get stable reading. It is normal for high resistance measurements.
4. When the input is not connected, i.e. at open circuit, the figure "OL" will be displayed for the overrange condition.

MEASURING FREQUENCY

1. Connect the red test lead to "VHz" jack and the black test lead to the "COM" jack.
2. Set the rotary switch at desired kHz position.
3. Connect test leads across the source or load being measured.
4. Read frequency value on the LCD display.

NOTE:

The input voltage should be between 200mV and 10V rms. ac. If the voltage is more than 10V rms. reading may be out of the accuracy range.

AUDIBLE CONTINUITY TEST

1. Connect red test lead to “ Ω ” jack, black test lead to “COM” jack. The polarity of red lead connection is positive “+”.
2. Set range switch to “•|) ” position.
3. Connect test leads to two points of circuit to be tested. If continuity exists, built-in buzzer will sound.

SPECIFICATIONS

Accuracy is specified for a period of one year after calibration and at 18°C to 28°C (64°F to 82°F) with relative humidity to 80%.

GENERAL

Maximum voltage between terminals and earth

ground: CAT II 1000V dc or 750V ac rms. (sine)

Display:

LCD, 3999 counts and 40 segments bar graph

Ranging method: Auto range

Polarity indication:

“ - ” Displayed for negative polarity

Overrange indication:

Only figure “OL” on the display

Jaw opening capability:

55mm (Max conductor size)

Power: 9V battery, NEDA 1604 6F22 006P

Low battery indication:

“  ” Appears on the display

Operating environment : 0°C to 40°C

Storage temperature: -10°C to 50°C

Temperature coefficient:

0.1 × specified accuracy /°C (<18°C or >28°C)

Altitude: 2000m

Size: 282mm × 104mm × 47mm

Weight: Approx. 570g

DC VOLTAGE

Range	Resolution	Accuracy
400mV	0.1mV	±0.8% of rdg ± 1 digit
4V	1mV	
40V	10mV	
400V	0.1V	
1000V	1V	±1.0% of rdg ± 2 digits

Input Impedance: 10MΩ

AC VOLTAGE (true rms., ac-coupled)

Range	Resolution	Accuracy
4V	1mV	±1.0% of rdg ± 5 digits
40V	10mV	
400V	0.1V	
750V	1V	±1.2 % of rdg ± 5 digits

Input Impedance: 10MΩ

Frequency range: 40Hz to 200Hz.

Response: True rms. Rms. conversion with signal crest factor: 5.

AC CURRENT (true rms., ac-coupled)

Range	Resolution	Accuracy
400A	0.1A	< 600A: ±2% of rdg ± 5 digits
1000A	1A	> 600A: ±3% of rdg ± 5 digits

Overload Protection: 1100A for 60 seconds maximum.

Frequency range: 50Hz to 60Hz.

DC CURRENT

Range	Resolution	Accuracy
400A	0.1A	< 600A: ±2% of rdg ± 5 digits
1000A	1A	> 600A: ±3% of rdg ± 5 digits

Overload Protection: 1100A for 60 seconds maximum.

RESISTANCE

Range	Resolution	Accuracy
400Ω	0.1Ω	±1.5% of rdg ± 5 digits
4kΩ	1Ω	
40kΩ	10Ω	
400kΩ	0.1kΩ	
4MΩ	1kΩ	
40MΩ	10kΩ	±2.5% of rdg ± 10 digits

Maximum Open Circuit Voltage: 0.5V

Overload Protection: 250V dc or rms. ac for all ranges.

FREQUENCY

Range	Resolution	Accuracy
4kHz	1Hz	±1.0% of rdg ± 5 digits
40kHz	10Hz	
400kHz	100Hz	

Sensitivity: 200mV rms.

AUDIBLE CONTINUITY

Range	Description
	If continuity exists (about less than 30Ω), built-in buzzer will sound.

AUTO POWER OFF

To extend the battery life, Auto Power Off function is provided. After the meter no operations about 30 minutes, the meter will be turned off automatically.

To turn it on need pushing the "REL" button only.

REPLACING THE BATTERY

WARNING

Before attempting to open the case of battery, always be sure that test leads have been disconnected from measurement circuits. Close case and tighten screws completely before using the meter to avoid electrical shock hazard.

If “” appears on display, it indicates that the battery should be replaced. Use the following procedure to replacing the battery:

1. Disconnect test leads from any live source, turn the rotary switch to OFF, and remove the test leads from the input terminals.
2. The battery cover is secured to the bottom case by a screw. Using a screwdriver, remove the screw from the battery cover and remove the battery

cover.

–17 –

3. Remove battery and replace with a new equivalent 9 volt battery.
4. Replace the battery cover and reinstall the screw.

ACCESSORIES

- Operator's instruction manual
- Set of test leads
- Gift box
- 9 volt battery. NEDA 1604 6F22 006P type

- 18 -

HYS004994