

Smart SMD Tester USER'S MANUAL

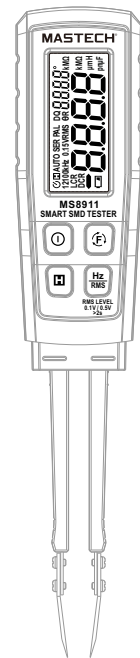

MASTECH®

1. Introduction

Thank you for purchasing a MS8911 smart SMD tester. The MS8911 smart SMD tester is a professional instrument for measuring inductance, capacitance and resistance. It has many features, such as automatic identification, automatic measurement range, high measurement accuracy and speed, wide measuring range and so on. An ordinary multimeter only provides DC mode for resistance measurement, while the MS8911 provides both AC and DC measurement modes. A variety of test frequencies up to 10Khz can be provided for inductance, capacitance and resistance in AC mode to meet the actual needs better. Correct usage can ensure that the instrument will work precisely for a long time. Please read the instructions carefully before using and operate the instrument strictly in accordance with the instructions.

Symbols

	Conforms to UL STD. 61010-1, 61010-2-032, 61010-2-033; Certified to CSA STD C22.2 NO. 61010-1, 61010-2-032, 61010-2-033
	Complies with European (EU) safety standards

MASTECH®

1.2 Panel description

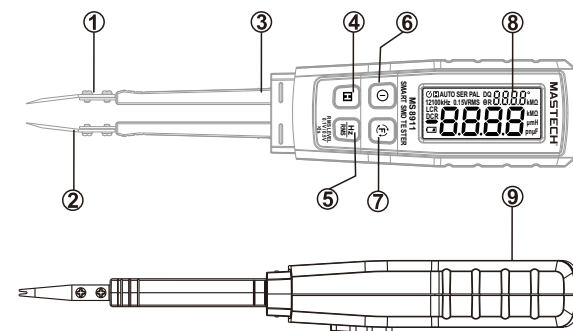

- ① Test Pin (Gold-plated)
- ② Test Pin (Gold-plated)
- ③ Pin Holder
- ④ "HOLD" Push Button
- ⑤ "Hz/RMS" Push Button
- ⑥ "POWER" Push Button
- ⑦ "function" Push Button
- ⑧ LCD
- ⑨ Battery cover

MASTECH®

1.3 Inspection

When you get a new LCR meter, please check the instrument and its accessories. If something is damaged or missed, please contact the store you bought the instrument from for adjustment or replacement.



2. Safety instructions:

- Operating environment and condition:
- Elevation <2000 m
 - Relative humidity (RH) ≤ 80 % RH
 - Operating temperature 0 - 40°C

Note: DO NOT input voltage at the measurement port. When measuring capacitance, please discharge first then measure, otherwise, the meter will be damaged. Storage and maintenance: Do not use alcohol or other solvents to clean the meter. If it will not be used for long time, please remove battery and put the meter in a dry and clean environment.

3. Description:

3.1 Definition Description

- APC: Auto power off
H: Display hold state

MASTECH®

AUTO: This character showing on the LCD means that the tester works in LCR automatic range mode
PAL: parallel connection measurement mode
SER: series connection measurement mode
C: Capacitance series/parallel connection measurement mode
L: Inductance series/parallel connection measurement mode
R: Resistance series /parallel connection measurement mode
DCR: Resistance DC measurement mode
D: Wastage factor
Q: Quality factor
12100KHZ: frequency
0.15VRMS: VRMS

3.1 Impedance parameter description (see Figure 1)

$Z = R_s + jX_s = |Z| \angle \theta$
 $R_s = |Z| \cos \theta$
 $X_s = |Z| \sin \theta$
If $\theta > 0$, it means that the measured object is inductive, if $\theta < 0$, it means that that the measured object is capacitive.

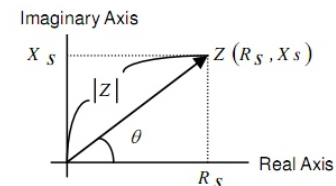

MASTECH®

3.2 Series-parallel connection mode description

This meter has series and parallel measurement modes. When the capacitance value of the measured object is large or inductance value is small, use the series mode for more accurate results. When the capacitance value of the measured object is small or inductance value is large, use the parallel mode for more accurate results. This meter can select the measurement mode automatically according to the measured object. When the measured impedance in 10KΩ below is set to SER(Series mode), when the measured impedance in 10KΩ above set to PAL (parallel mode).

4. Functional characteristics description:

1. 6000 count
2. LC automatic range measurement
3. R analytical measurement
4. DCR mode of resistance measurement
5. D/Q display: The automatic selection for the C+D/L+Q/R+Q
6. Measuring voltage : 0.5VRMS/0.1VRMS
7. The test frequency AC mode : 100/120/1k/10k/
8. Battery electric power display : Long time not to operate the power off automatically
9. See table 1-3 for measurement accuracy and scope

Remarks: This accuracy is the measurement standard. In DUT jack, the meter-specific probe should be used if required. Measurement with probe may be influenced by external environment. To avoid inaccurate measurements, please keep away from strong magnetic sources.

MASTECH®

Table 1 Resistance measurement scope

Measuring voltage	Range	Accuracy
0.5VRMS	60.00Ω	2.0%+10d
0.5VRMS	600.0Ω	1.0%+5d
0.5VRMS	6.000KΩ	1.0%+5d
0.5VRMS	60.00KΩ	1.0%+5d
0.5VRMS	600.0KΩ	1.0%+5d
0.5VRMS	6.000MΩ	2.0%+5d
0.5VRMS	20.00MΩ	2.0%+5d
0.1VRMS	60.00Ω	2.0%+10d
0.1VRMS	600.0Ω	1.5%+5d
0.1VRMS	6.000KΩ	1.5%+5d
0.1VRMS	60.00KΩ	1.5%+5d
0.5VRMS	600.0KΩ	1.5%+5d
0.1VRMS	6.000MΩ	3.0%+5d
0.1VRMS	20.00MΩ	3.0%+5d

Note: The accuracy of Q < 0.1 assessment criteria
Measurement Frequencies:
 (100HZ/120HZ/1KHZ/10KHZ:60.00Ω~6MΩ position)
 (100HZ/120HZ/1KHZ/ :20MΩ position)
 minimum resolution:0.1Ω
 minimum test range:>0.1Ω

06

MASTECH®

Table 2 Capacitance measurement scope

Measuring voltage	Range	Accuracy
0.5VRMS	600.0pF	2.0%+8d
0.5VRMS	6.000nF	1.0%+5d
0.5VRMS	60.00nF	1.0%+5d
0.5VRMS	600.0nF	1.0%+5d
0.5VRMS	6.000uF	2.0%+5d
0.5VRMS	60.00uF	2.0%+5d
0.5VRMS	600.0uF	2.0%+10d
0.5VRMS	6.000mF	2.0%+5d
0.1VRMS	600.0pF	2.0%+5d
0.1VRMS	6.000nF	1.5%+5d
0.1VRMS	60.00nF	1.5%+5d
0.1VRMS	600.0nF	1.5%+5d
0.1VRMS	6.000uF	1.5%+5d
0.1VRMS	60.00uF	3.0%+5d
0.1VRMS	600.0uF	3.0%+5d
0.1VRMS	6.000mF	3.0%+5d

07

MASTECH®

Note: This accuracy is the measurement standard when D < 0.1, if D > 0.1, it should be multiplied by the extraction of a root of 1.5
Measurement Frequencies:
 (100HZ/120HZ:60.00nF~600.0nF~6.000uF~60.00uF~600.0uF~6.000mF position)
 (1KHZ:60.00nF~600.0nF~6.000uF~60.00uF~600.0uF position, (10KHZ:600.0pF~6.000nF~60.00nF~600.0nF~6.000uF position)
 minimum resolution:0.1pF
 minimum test range:>0.8pF

Table 3. Inductance measurement scope

Measuring voltage	Range	Accuracy
0.5VRMS	600.0uH	2.0%+5d
0.5VRMS	6000uH	2.0%+5d
0.5VRMS	60.00mH	1.0%+5d
0.5VRMS	600.0mH	1.0%+5d
0.5VRMS	6.000H	1.0%+5d
0.5VRMS	60.00H	1.0%+5d
0.5VRMS	200.0H	2.0%+5d
0.1VRMS	600.0uH	3.0%+5d
0.1VRMS	6000uH	3.0%+5d
0.1VRMS	60.00mH	1.5%+5d
0.1VRMS	600.0mH	1.5%+5d

08

MASTECH®

0.1VRMS	6.000H	1.5%+5d
0.1VRMS	60.00H	1.0%+5d
0.1VRMS	200.0H	2.0%+5d

Note: This accuracy is the measurement standard when D < 0.1, if D > 0.1, it should be multiplied by the extraction of a root of 1.5
Measurement Frequencies:
 (100HZ/120HZ:60.00mH~600.0mH~6.000H~60.00H~200.0H position)
 (1KHZ:6000uH~60.00mH~600.0mH~6.000H~60.00H position).
 (10KHZ:600.0uH~6000uH~60.00mH~600.0mH~6.000H position)
 minimum resolution:0.1uH
 minimum test range:>1.6uH

Table 4:DCR resistance measurement scope

Measuring voltage	Range	Accuracy
0.5VRMS	60.00Ω	2.0%+10d
0.5VRMS	600.0Ω	1.0%+5d
0.5VRMS	6.000KΩ	1.0%+5d
0.5VRMS	60.00KΩ	1.0%+5d
0.5VRMS	600.0KΩ	1.0%+5d
0.5VRMS	6.000MΩ	2.0%+5d
0.5VRMS	20.00MΩ	2.0%+5d

minimum resolution:0.01Ω

09

MASTECH®

4 Measurement operation description:

4.1 Power on/off function:

Short press the "POWER" key to activate the meter and long press for one second to shut it down.

4.2 Parameter selection function

In AC mode, each press the "Hz / RMS" key for a short time, you will switch the test frequency to 100Hz->120Hz->1KHz->10KHz->100Hz press the "Hz / RMS" key for one second, you will switch the measure voltage to 0.5VRMS-> 0.1VRMS-> 0.5VRMS .

4.3 Measuring function

When the meter after start up, the default is LCR automatic measure range mode, short press the "function" key then enter the R single measurement mode, and press again can change the single measurement mode, like R->DCR->L->C->R. long press the "function" key, return back to automatic measurement range mode.

4.4 Data Hold function:

press "H" button to stop reading measurement value and show the current measurement value on the main display continuously.

10

MASTECH®

5. Additional functions

5.1 Auto power off function: The instrument will automatically power off without any operation for 5 minutes.

5.2 Battery power detection function

The meter has a battery power detection function. When  displays for battery, please replace battery. This meter uses 3V*1 CR2450 button battery. Batteries with the same model should be used for battery replacement. Please remember that you can't use the meter until the rear cover is tightened.



11

R-00-05-1985