

SMOKE & CO COMBO ALARM PHOTOELECTRIC

«(• WIRELESS INTERCONNECT •)»

CAT. **SC0500B**



WIRELESS INTERCONNECT

Reliable and secure radio frequency communication between alarms. 915 MHz frequency with 65,000 security codes and 3 channel frequency hopping.

TALKING ALARM WITH LOCATION

When programmed, a voice will tell you the location of unit if smoke is detected.

MESH NETWORK COMMUNICATION

2-way communication format that sends, receives and re-sends the alarm signals providing a more reliable network.

PHOTOELECTRIC

Photoelectric technology is generally more sensitive at detecting large particles, which tend to be produced in greater amounts by smoldering fires.

SILENCE FEATURE

Silences nuisance alarms.

TAMPER RESISTANT

Locks alarm to mounting bracket to prevent removal of battery and/or alarm. Perfect for apartment, dormitory or hotel applications.



PHOTOELECTRIC

Listed to
UL 217 &
UL 2034
Standards

BRK®

THE PROFESSIONAL STANDARD

3V (2 AA) Battery Powered

Description:

BRK SC0500B (model SC0500) is a single station combination smoke and CO alarm specifically designed for residential and institutional applications including sleeping rooms of hospitals, hotels, motels, dormitories, and other multifamily dwellings as defined in standard NFPA 101. BRK SC0500B has been fully tested and complies with, UL217, UL2034, CSFM, NFPA 72, NFPA 720 and NFPA 101 and other agencies that model their codes after the above agencies. It meets building codes where battery operated smoke and CO alarms are required either separately or in combination along with wireless interconnect, voice with location and silence features and with model building codes published by the ICC.

BRK SC0500B is a state of the art wireless talking combination smoke and CO alarm designed to provide early warning of a fire or CO. It features a fully insect screened Photoelectric smoke sensing chamber and an electrochemical carbon monoxide sensor, an 85dB horn, a supervised 3V (2 AA batteries) power supply, a full function test switch and a silence feature. This combination alarm interconnects via wireless communication on a reliable and secure radio frequency communication of 915 MHz frequency with 65,000 security codes and 3 channel frequency hopping. You have a choice of 11 pre-programmed locations where a voice will announce the location and danger detected. When interconnected with other BRK Wireless Interconnect alarms it will also announce the danger and location detected of that alarm too. It operates on a Mesh Network; a two-way communication format that sends, receives and re-sends the alarm signals providing a more reliable network. It also features tamper resistant locking pins that lock alarm to the mounting bracket and battery drawer to prevent removal of battery or alarm. Perfect for apartment, dormitory or hotel applications. Designed for wall or ceiling mounting. Includes mounting anchors and screws.

Voice Warning!
WITH LOCATION

CAT. SC0500B

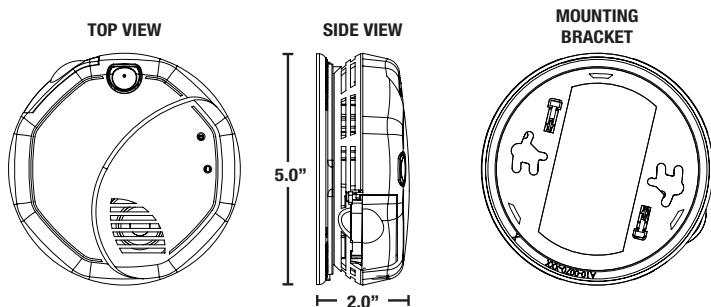

ARCHITECTURAL AND ENGINEERING SPEC

The combination smoke and CO alarm shall be a BRK Model SC0500 (cat. no. SC0500B) and shall provide at a minimum the following features and functions:

1. A photoelectric smoke sensing chamber and an electrochemical CO sensor.
2. Wireless interconnect: 915 MHz frequency with 65,000 security codes and 3 channel frequency hopping.
3. A Voice Warning of danger detected in addition to speaking one of 11 pre-programmed locations, e.g. "Warning, Evacuate, Smoke in Basement".
4. Operates on a Mesh Network; a two-way communication format that sends, receives and re-sends the alarm signals providing a more reliable network.
5. The unit shall have a lower and varying horn frequency to make it easier for the elderly with normal age related hearing loss to better hear the horn.
6. The CO sensor is adjusted not to detect CO levels below 30 PPM and will not alarm when exposed to constant levels of 30 PPM for 30 days. It will alarm at the following levels: 400 PPM CO between 4 and 15 minutes, 150 PPM CO between 10 and 50 minutes and 70 PPM CO between 60 and 240 minutes.
7. The unit shall have an "End of Life" signal. This signal should be capable of temporarily being silenced for up to 2 days. After about 2 days, the signal will resume. After about 2-3 weeks the signal cannot be silenced.
8. A fully screened sensing chamber to resist entry of small insects.
9. Powered by 2 replaceable AA batteries, a solid state horn rated at 85dB at 10 ft and should be capable of self restoring.
10. A visual LED power-on indicator to confirm unit is receiving power or is in alarm.
11. Two Silence features - Low Battery Silence: Silence low battery chirp for up to 8 hours. Alarm Silence: Temporarily silence unwanted nuisance alarms.
12. Two Locking features - tamper resistant locking pins that lock battery drawer and/or alarm to mounting bracket.
13. The unit shall be capable of operating between 40°F (4°C) and 100°F (38°C) and relative humidity between 10% and 95%.
14. The unit shall contain mounting hardware and shall be listed for wall or ceiling mounting.
15. The unit shall at a minimum meet the requirements of UL217, UL2034, CSFM, NFPA 72, NFPA 720, NFPA 101, ICC.

INSTALLATION OF ALARM

Installation of this alarm must conform to NFPA 72 and NFPA 720. Always check your local building codes. Follow all instructions for placement as outlined in the user's manual in sections titled "Recommended Locations for Smoke Alarms" and "Locations to Avoid for Smoke Alarms".

THE PARTS OF THIS ALARM

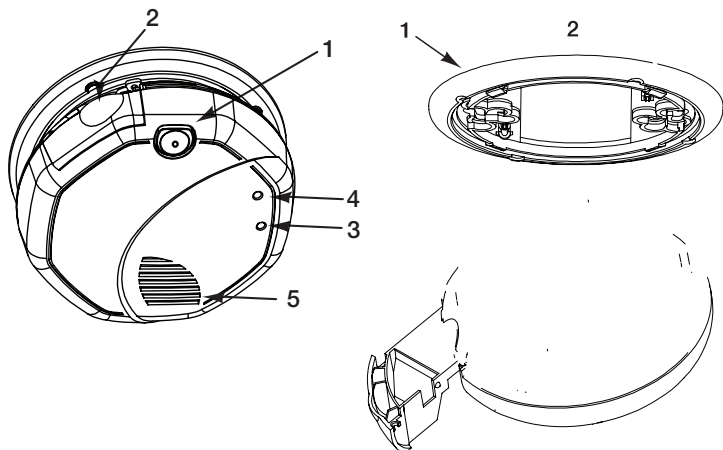

TECHNICAL SPECS

Alarm Dimensions:	5.0" Dia. x 2.0"H
Weight:	8.4 oz
Operating Voltage:	3V (Two 1.5V AA) Battery Powered
Temperature Range:	40°F (4°C) to 100°F (38°C)
Humidity Range:	10% to 95% relative humidity (RH)
Audio Alarm:	85dB at 10 feet
Voice Output:	Choice of 11 pre-programmed locations
Wireless Frequency:	915 MHz. FCC approved. Complies with Part 15 of the FCC Rules.
RF Linking:	Automatic with 65,000 security codes
Test/Silence:	Electronically simulates smoke and CO condition, causing the unit to alarm. Press and hold test/silence button.
Alarm Reset:	Automatic when smoke and/or CO clears
Smoke Sensor:	Photoelectric
CO Sensor:	Electrochemical
Interconnections:	Up to 18 units, RF or hardwired (needs SA520B Bridge Unit), with smoke, carbon monoxide, heat alarms and relays. Maximum 12 smoke alarms.
Listing:	Listed to UL217 and UL2034 Standards

SHIPPING SPECS

Individual Carton Dimensions	5.13"L x 2.38"W x 5.13"H
Weight	0.66 lbs.
Cube	0.04 ft ³
UPC	0 29054 51306 9
Master Carton Dimensions	10.75"L x 7.88"W x 11.06"H
Master Pack	12
Weight	8.4 lbs.
Cube:	0.54 ft ³
I2of5:	100 29054 51306 6
Pallet Information	
Cases per Layer	22
Number of Layers:	4
Cases per Pallet:	88
Units per Pallet:	1,056
Cube:	54 ft ³
Weight:	794 lbs.

TOP OF ALARM

1. Test/Silence button
2. Slide open battery drawer
3. Power/Alarm LED
4. CO Alarm LED
5. Horn

BOTTOM OF ALARM

1. Mounting bracket
2. Mounting Slots & Locking tabs (Break out Tab)
3. Battery Drawer - Install 2 AA batteries here
4. Twist to attach and remove alarm from bracket