

# E80H Series Incremental Ø80mm Hollow Shaft Type

## Hollow Shaft Type Ø80mm Incremental Rotary Encoder

### ■ Features

- Ø80mm, Inner diameter of shaft Ø30mm, Ø32mm
- No coupling needed with direct installation at motor or rotation shaft of machine
- Power supply: 5VDC, 12-24VDC ±5%
- Various output types



⚠ Please read "Caution for your safety" in operation manual before using.



### ■ Ordering Information

<b>E80H</b>	<b>30</b>	<b>-</b>	<b>3200</b>	<b>-</b>	<b>3</b>	<b>-</b>	<b>N</b>	<b>-</b>	<b>24</b>	<b>-</b>	
-------------	-----------	----------	-------------	----------	----------	----------	----------	----------	-----------	----------	--

Series	Shaft diameter	Pulses/revolution	Output phase	Control output	Power supply	Cable
Ø80mm, hollow shaft type	30: Ø30mm 32: Ø32mm	60, 100, 360, 500, 512, 1024, 3200	3: A, B, Z 6: A, $\bar{A}$ , B, $\bar{B}$ , Z, $\bar{Z}$	T: Totem pole output N: NPN open collector output V: Voltage output L: Line driver output	5: 5VDC ±5% 24: 12-24VDC ±5%	No mark: Radial cable type C: Radial cable connector type

### ■ Specifications

Item	Hollow Shaft Type Ø80mm Incremental Rotary Encoder		
Resolution (PPR) <sup>※1</sup>	60, 100, 360, 500, 512, 1024, 3200		
Electrical specification	Output phase	A, B, Z phase (line driver output A, $\bar{A}$ , B, $\bar{B}$ , Z, $\bar{Z}$ phase)	
	Phase difference of output	Output between A and B phase: $\frac{T}{4} \pm \frac{T}{8}$ (T=1 cycle of A phase)	
	Control output	Totem pole output	• [Low] - Load current: Max. 30mA, Residual voltage: Max. 0.4VDC • [High] - Load current: Max. 10mA, Output voltage (power voltage 5VDC): Min. (power voltage-2.0)VDC, Output voltage (power voltage 12-24VDC): Min. (power voltage-3.0)VDC
		NPN open collector output	Load current: Max. 30mA, Residual voltage: Max. 0.4VDC
		Voltage output	Load current: Max. 10mA, Residual voltage: Max. 0.4VDC
		Line driver output	• [Low] - Load current: Max. 20mA, Residual voltage: Max. 0.5VDC • [High] - Load current: Max. -20mA, Output voltage (power voltage 5VDC): Min. 2.5VDC, Output voltage (power voltage 12-24VDC): Min. (power voltage-3.0)VDC
	Response time (rise, fall)	Totem pole output	Max. 1μs (cable length: 2m, I sink = 20mA)
		NPN open collector output	
		Voltage output	
		Line driver output	Max. 0.5μs (cable length: 2m, I sink = 20mA)
	Max. response frequency	200kHz	
	Power supply	• 5VDC ±5% (ripple P-P: Max. 5%) • 12-24VDC ±5% (ripple P-P: Max. 5%)	
	Current consumption	Max. 80mA (disconnection of the load), Line driver output: Max. 50mA (disconnection of the load)	
	Insulation resistance	Over 100MΩ (at 500VDC megger between all terminals and case)	
	Dielectric strength	750VAC 50/60Hz for 1 minute (between all terminals and case)	
Connection	Radial cable type, Radial cable connector type		
Mechanical specification	Starting torque	Max. 200gf·cm (0.0196N·m)	
	Moment of inertia	Max. 800g·cm <sup>2</sup> (8×10 <sup>-5</sup> kg·m <sup>2</sup> )	
	Shaft loading	Radial: Max. 5kgf, Thrust: Max. 2.5kgf	
	Max. allowable revolution <sup>※2</sup>	3,600rpm	
Vibration	1.5mm amplitude at frequency of 10 to 55Hz (for 1 min) in each X, Y, Z direction for 2 hours		
Shock	Approx. max. 75G		
Environment	Ambient temperature	-10 to 70°C, storage: -25 to 85°C	
	Ambient humidity	35 to 85%RH, storage: 35 to 90%RH	
Protection structure	IP50 (IEC standard)		
Cable	Ø5mm, 5-wire (line driver output: 8-wire), 2m, Shield cable (AWG24, core diameter: 0.08mm, number of cores: 40, insulator out diameter: Ø1mm)		
Accessory	Spring bracket		
Approval	CE (except for line driver output)		
Unit weight	Approx. 560g		

※1: Not indicated resolutions are customizable.

※2: Make sure that max. response revolution should be lower than or equal to max. allowable revolution when selecting the resolution.

$$[\text{Max. response revolution (rpm)}] = \frac{\text{Max. response frequency}}{\text{Resolution}} \times 60 \text{ sec}$$

※Environment resistance is rated at no freezing or condensation.

(A) Photoelectric Sensors

(B) Fiber Optic Sensors

(C) Door/Area Sensors

(D) Proximity Sensors

(E) Pressure Sensors

(F) Rotary Encoders

(G) Connectors/  
Connector Cables/  
Sensor Distribution  
Boxes/Sockets

(H) Temperature Controllers

(I) SSRs / Power Controllers

(J) Counters

(K) Timers

(L) Panel Meters

(M) Tacho / Speed / Pulse Meters

(N) Display Units

(O) Sensor Controllers

(P) Switching Mode Power Supplies

(Q) Stepper Motors & Drivers & Controllers

(R) Graphic/ Logic Panels

(S) Field Network Devices

(T) Software

# E80H Series

## Control Output Diagram

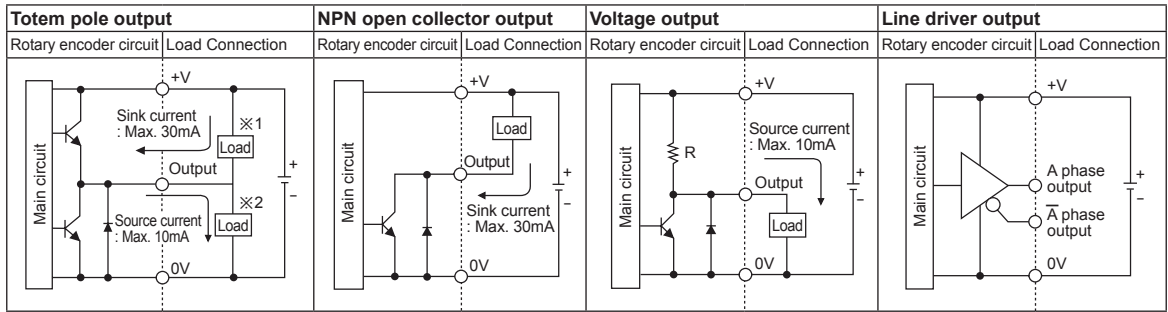

- All output circuits of A, B, Z phase are same. (line driver output is A,  $\bar{A}$ , B,  $\bar{B}$ , Z,  $\bar{Z}$ )
- Totem pole output type can be used for NPN open collector type (※1) or voltage output type (※2).

## Output Waveforms

- Totem pole output / NPN open collector output / Voltage output

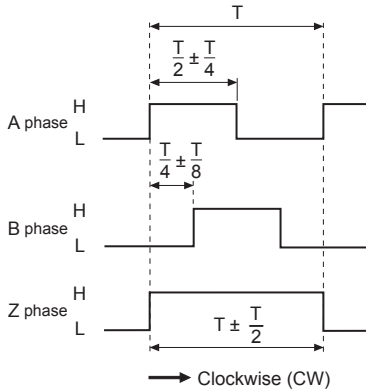

- Line driver output

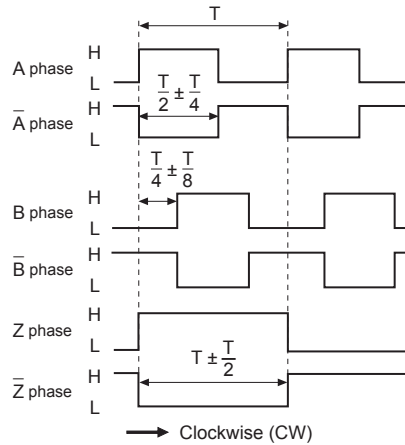

## Connections

### Radial cable type

- Totem pole output / NPN open collector output / Voltage output

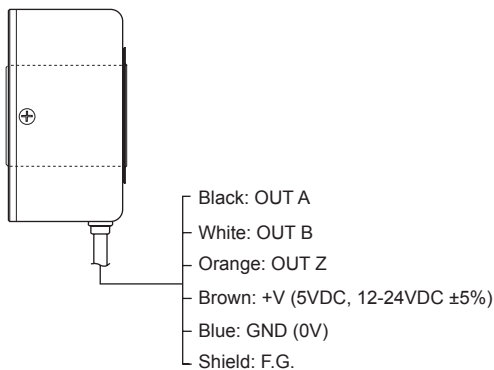

- Line driver output

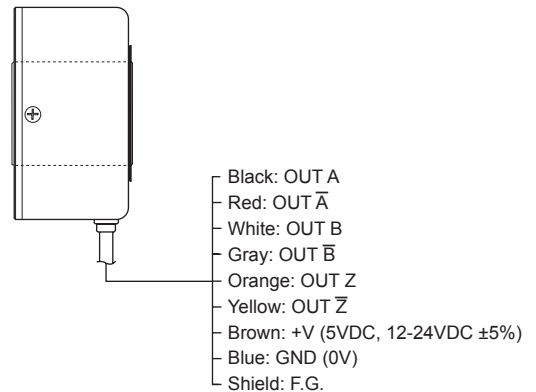

※ Unused wires must be insulated.

※ The metal case and shield cable of encoder should be grounded (F.G.).

# Incremental Ø80mm Hollow Shaft Type

## ■ Connections

### ◎ Radial cable connector type

- Totem pole output / NPN open collector output / Voltage output



- Line driver output



• Totem pole output • NPN open collector output • Voltage output			• Line driver output		
Pin No.	Function	Cable color	Pin No.	Function	Cable color
1	OUT A	Black	1	OUT A	Black
2	OUT B	White	2	OUT A	Red
3	OUT Z	Orange	3	+V	Brown
4	+V	Brown	4	GND	Blue
5	GND	Blue	5	OUT B	White
6	F.G.	Shield	6	OUT B	Gray
			7	OUT Z	Orange
			8	OUT Z	Yellow
			9	F.G.	Shield

※F.G. (field ground): It should be grounded separately.

## ■ Dimensions

### ◎ Radial cable type

(unit: mm)

- Shaft inner diameter = Ø30mm

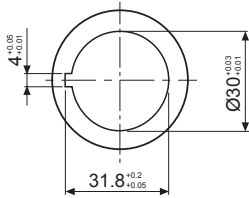

- Shaft inner diameter = Ø32mm

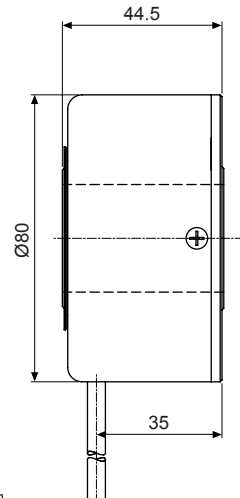
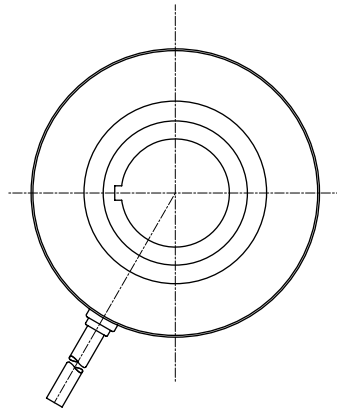
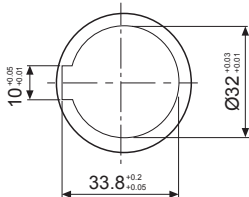

Cable for Radial cable type  
Ø5mm, 5-wire (line driver output: 8-wire),  
2000mm, Shield cable

### ◎ Radial cable connector type

- Bracket

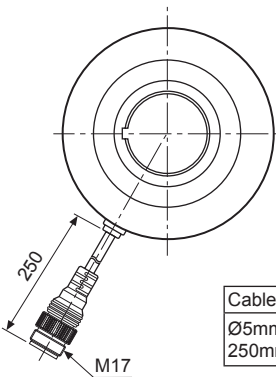

Cable for Radial cable connector type  
Ø5mm, 5-wire (line driver output: 8-wire),  
250mm, Shield cable

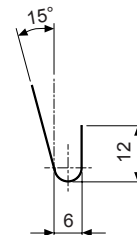
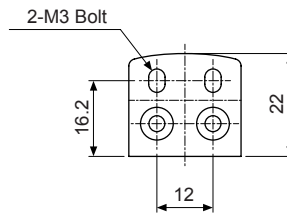

※Connector cable is sold separately and refer to page G-10 for specifications.

(A) Photoelectric Sensors

(B) Fiber Optic Sensors

(C) Door/Area Sensors

(D) Proximity Sensors

(E) Pressure Sensors

(F) Rotary Encoders

(G) Connectors/  
Connector Cables/  
Sensor Distribution  
Boxes/Sockets

(H) Temperature Controllers

(I) SSRs / Power Controllers

(J) Counters

(K) Timers

(L) Panel Meters

(M) Tacho / Speed / Pulse Meters

(N) Display Units

(O) Sensor Controllers

(P) Switching Mode Power Supplies

(Q) Stepper Motors & Drivers & Controllers

(R) Graphic/ Logic Panels

(S) Field Network Devices

(T) Software